	<b>ITTC – Recommended Procedures and Guidelines</b>	<b>7.5 - 02 06 - 02</b> Page 1 of 27	
	<b>Testing and Extrapolation Methods Manoeuvrability Captive Model Test Procedures</b>	Effective Date 2005	Revision 02

## Table of Contents

<p><b>1. PURPOSE OF PROCEDURE.....2</b></p> <p><b>2. DESCRIPTION OF PROCEDURE ....2</b></p> <p style="padding-left: 20px;"><b>2.1 Preparation .....2</b></p> <p style="padding-left: 40px;">2.1.1 Selection of model dimensions.....2</p> <p style="padding-left: 40px;">2.1.2 Model inspection .....4</p> <p style="padding-left: 40px;">2.1.3 Model equipment and set-up .....4</p> <p style="padding-left: 20px;"><b>2.2 General Considerations.....4</b></p> <p style="padding-left: 40px;">2.2.1 Kinematic parameters .....4</p> <p style="padding-left: 40px;">2.2.2 Ship control parameters .....5</p> <p style="padding-left: 40px;">2.2.3 Operational and analysis parameters .....5</p> <p style="padding-left: 20px;"><b>2.3 Execution of the Tests .....5</b></p> <p style="padding-left: 40px;">2.3.1 Stationary straight-line tests .....5</p> <p style="padding-left: 40px;">2.3.2 Harmonic tests .....7</p> <p style="padding-left: 40px;">2.3.3 Stationary circular tests .....10</p> <p style="padding-left: 20px;"><b>2.4 Data acquisition and analysis .....11</b></p> <p style="padding-left: 40px;">2.4.1 Measured data.....11</p> <p style="padding-left: 40px;">2.4.2 Data acquisition .....11</p> <p style="padding-left: 40px;">2.4.3 Visual inspection .....11</p> <p style="padding-left: 40px;">2.4.4 Analysis methods.....12</p> <p style="padding-left: 40px;">2.4.5 Analysis of forces .....12</p> <p style="padding-left: 20px;"><b>2.5 Prediction procedure.....12</b></p> <p style="padding-left: 20px;"><b>2.6 Documentation .....12</b></p> <p style="padding-left: 40px;">2.6.1 Experimental technique .....12</p> <p style="padding-left: 40px;">2.6.2 Analysis procedure .....14</p> <p><b>3. PARAMETERS .....14</b></p>	<p><b>3.1 Parameters to be taken into account.....14</b></p> <p style="padding-left: 20px;">3.1.1 General .....14</p> <p style="padding-left: 20px;">3.1.2 Stationary straight line tests .....15</p> <p style="padding-left: 20px;">3.1.3 Harmonic tests .....15</p> <p style="padding-left: 20px;">3.1.4 Stationary circular tests .....15</p> <p><b>4. VALIDATION .....15</b></p> <p style="padding-left: 20px;"><b>4.1 Causes of uncertainty .....15</b></p> <p style="padding-left: 40px;">4.1.1 Imperfections causing errors to the boundary and/or initial conditions.15</p> <p style="padding-left: 40px;">4.1.2 Imperfections with direct or indirect influence on the ship model's dynamics.....16</p> <p style="padding-left: 40px;">4.1.3 Interpretation errors due to limitations of signal generation and manipulation.....17</p> <p style="padding-left: 20px;"><b>4.2 Uncertainty analysis .....18</b></p> <p style="padding-left: 40px;">4.2.1 Trajectory .....18</p> <p style="padding-left: 40px;">4.2.2 Kinematics .....19</p> <p style="padding-left: 40px;">4.2.3 Dynamics .....20</p> <p style="padding-left: 40px;">4.2.4 Data acquisition .....20</p> <p style="padding-left: 40px;">4.2.5 Numerical analysis .....20</p> <p style="padding-left: 40px;">4.2.6 Influence of ship model's dynamics on forces and moments .....22</p> <p style="padding-left: 20px;"><b>4.3 Benchmark Tests .....26</b></p> <p><b>5. REFERENCES .....26</b></p>
--	--

Updated / Edited by	Approved
Name of the Committee	24 <sup>th</sup> ITTC 2005
Date 2005	Date 09 2005

	<b>ITTC – Recommended Procedures and Guidelines</b>	<b>7.5 - 02 06 - 02.2</b> Page 2 of 27	
	<b>Testing and Extrapolation Methods Manoeuvrability Captive Model Test Procedures</b>	Effective Date 2005	Revision 02

## Captive Model Test Procedure

### 1. PURPOSE OF PROCEDURE

Captive model test techniques are applied to determine the hydrodynamic coefficients for a mathematical model of ship manoeuvring motion. It should be noted that hydrodynamic force coefficients may be determined by other means, e.g. by system identification techniques applied to free-running model test results.

Taking account of the mechanism involved and the motion imposed to the ship model, a distinction can be made between:

a) stationary straight line tests, performed in a towing tank:

- (a1) straight towing;
- (a2) straight towing with rudder deflection;
- (a3) oblique towing;
- (a4) oblique towing with rudder deflection;

b) harmonic tests, requiring a towing tank equipped with a PMM:

- (b1) pure sway;
- (b2) pure yaw;
- (b3) pure yaw with rudder deflection;
- (b4) pure yaw with drift.

c) stationary circular tests, by means of a rotating arm or an  $xy$ -carriage:

- (c1) pure yaw;
- (c2) yaw with drift;
- (c3) yaw with rudder deflection;
- (c4) yaw with drift and rudder deflection;

Tests a1, a3, b1, b2, b4, c1, c2 are carried out for determining hull forces; a2, a4, b3, c3, c4 yield rudder induced forces, and are therefore non-applicable in case the model is not fitted with rudder and propeller (bare hull testing).

Standard procedures for these types of tests are presented, together with recommended quantitative guidelines in order to ensure the quality of test results and to obtain reliable results. The procedure is to be used for surface ships only, where Froude scaling is applied.

These guidelines are mainly based on the "Recommended standard PMM test procedure" formulated by the 21<sup>st</sup> ITTC Manoeuvring Committee (1996), but also contain quantitative data which are based on two sources: literature on captive testing published during the last decades, and the results of a questionnaire distributed among all ITTC member organisations in 1997 (22<sup>nd</sup> ITTC Manoeuvring Committee, 1999).

Furthermore, the main principles of an analysis procedure for the uncertainty of the results are suggested.

### 2. DESCRIPTION OF PROCEDURE

#### 2.1 Preparation

##### 2.1.1 Selection of model dimensions.

Following considerations should be made for selecting the scale and, therefore, the model dimensions.

 INTERNATIONAL TOWING TANK CONFERENCE	<b>ITTC – Recommended Procedures and Guidelines</b>	<b>7.5 - 02</b> <b>06 - 02.2</b> Page 3 of 27	
	<b>Testing and Extrapolation Methods Manoeuvrability Captive Model Test Procedures</b>	Effective Date 2005	Revision 02

### 2.1.1.1 Scale

Principally, the scale should be chosen as large as possible, keeping in mind that scale effects in manoeuvring are not yet fully understood.

### 2.1.1.2 Model length

According to actual practice (see Figure 1) for test types (a) and (b), a model length of 3 m is frequently selected, the mean value being 4.5 m. 95 % of all captive model tests are carried out with a model length not less than 2 m.

On the average, circular tests (c) are performed with smaller models (mean length of 3 m, peak in the distribution at 2.2 m, 95% limit 1.5 m).

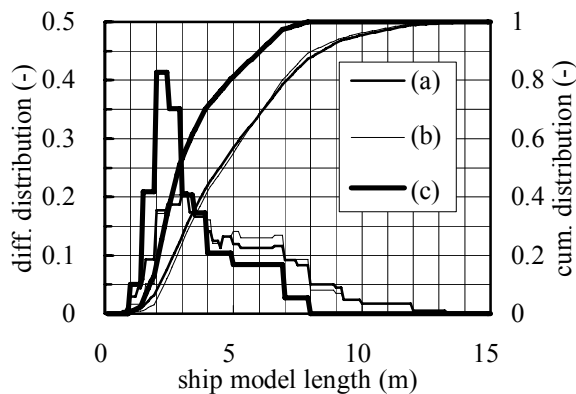

Figure 1: Differential and cumulative distribution of the length of ship models used for several types of captive model tests.

Minimum model dimensions may be based on considerations about rudder and propeller mounting, and on a minimum Reynolds number for appendages and propeller.

### 2.1.1.3 Ratios of model to tank dimensions

In order to avoid interference between the model and the tank boundaries and to guarantee a minimum measuring time or measuring distance, the model dimensions should not exceed some upper limit.

- Most tests of types (a) and (b) are carried out in a towing tank with a length of 35 times the ship model length and more. A mean value for the model length to tank width ratio ( $L/b$ ) is 0.47 for stationary straight line tests (a), and somewhat smaller (0.42) for harmonic tests (c).
- For rotating arm tests, the selection of the model length determines maximum and minimum values for  $L/R$ . Most circular tests (b) are carried out in a tank the largest dimension of which is about 20 times the model length. As most circular tests are executed in circular or wide tanks, the mean value of  $L/b$  is much smaller (0.09) compared with tests of types (a) and (c).

### 2.1.1.4 Water depth

For the deep water case, the depth to draft ratio should be large enough to be free from shallow water effects. Referring to IMO (MSC/Cir 644), a minimum value of  $h/T = 4$  is considered as acceptable. This figure, which accounts for practical issues of full scale trials, must be considered as a strict minimum for model tests. The test speed should be below  $0.75 (gh)^{1/2}$ .

For shallow water tests the depth should be scaled correctly; this may impose a restriction on the maximum draft. At very small  $h/T$ , the waviness of the tank bottom should be less than 10% of the under keel clearance, which may determine the minimum draft.

	<b>ITTC – Recommended Procedures and Guidelines</b>	<b>7.5 - 02 06 - 02.2</b> Page 4 of 27	
	<b>Testing and Extrapolation Methods Manoeuvrability Captive Model Test Procedures</b>	Effective Date 2005	Revision 02

### 2.1.2 Model inspection

The model should be inspected, prior to launching and testing, for:

- main dimensions,
- hull configuration,
- model mass,
- centre of gravity position (longitudinal; also vertical, if measurements concerning roll are required, or roll is not fixed),
- moments of inertia (about vertical  $z$ -axis if yawing tests are performed; also about longitudinal  $x$ -axis if roll is important, and about transversal  $y$ -axis for particular vessels).

### 2.1.3 Model equipment and set-up

The model is usually connected to the driving mechanism such that it is free in heave and pitch, and fixed in roll. For some tests, it may be free to roll, or rolling may be forced; for 3 DOF simulations in which roll is not included, and is therefore assumed to be negligible, it is often decided, and may be better, to prevent roll motions than to let the model roll freely.

In particular cases, the model may be constrained in all degrees of freedom.

Great care must be taken when aligning the model with respect to the tank reference axis; this should be checked before and after testing. For tests performed in a towing tank (a and b), the alignment can be checked using pure drift tests at small angles (between  $\pm 2^\circ$ ). The “zero drift angle” position is obtained when side forces and yaw moment are both minimum. It must however be remembered that the dissymmetry of the model (appendages alignment, propeller loading...) may lead to non zero side forces/yawing moment for zero drift angle.

The loading condition of the model (fore and aft draft) should be checked before experiments and verified before and after the tests.

## 2.2 General Considerations

The planning of a captive model test program for determining numerical values of the coefficients occurring in a mathematical manoeuvring model requires the selection of a number of parameters. Distinction can be made between three kinds of parameters.

### 2.2.1 Kinematic parameters

A first series of parameters is related to the range of kinematical variables occurring in the mathematical model:

- value(s) of the forward speed component  $u$ ,
- values of the parameters characterising sway, yaw and, when applicable, roll motions, depending on the type of experiment, and the kind of motions the mechanism is able to perform, and should be selected taking account of the application field of the mathematical model (e.g. indication of course stability, prediction of standard manoeuvres, simulation of harbour manoeuvres).

Concerning the selection of kinematic parameters, a number of common requirements can be formulated.

- The ranges of the non-dimensional values for sway and yaw velocity should be sufficiently large. The lower limit should be sufficiently small for an accurate determination of the course stability derivatives; the determination of the complete mathematical model requires maximum values that are large enough to cover the range explored during simulations.

 INTERNATIONAL TOWING TANK CONFERENCE	<b>ITTC – Recommended Procedures and Guidelines</b>				<b>7.5 - 02 06 - 02.2</b> Page 5 of 27	
	<b>Testing and Extrapolation Methods Manoeuvrability Captive Model Test Procedures</b>				Effective Date 2005	Revision 02

- The order of magnitude of the velocity and acceleration components should be in the range of the values of the real full scale ship.
- The induced wake patterns should be in accordance with the application field of the mathematical model. Past viscous wake and wave patterns should not interfere with the model trajectory.
- If non-stationary techniques are applied (e.g. PMM testing), the quasi-stationary character of the mathematical models should be taken into account. Test results should not be affected by memory effects; this will permit their extrapolation to zero frequency.

	forward speeds				propeller loadings					
	cum. distr. (%)				max	cum. distr. (%)				max
	0	50	80	100	freq	0	50	80	100	freq
b	1	1	3	10	1	1	1	1	10	1

	drift angles				rudder angles					
	cum. distr. (%)				max	cum. distr. (%)				max
	0	50	80	100	freq	0	50	80	100	freq
b1	-	-	-	-	-	1	1	1	10	1
b3	-	-	-	-	-	2	3	4	6	3
b4	2	4	6	10	4	1	1	4	10	1

Table 1: Test types (a) and (b): number of test parameters

### 2.2.2 Ship control parameters

The second kind of parameters is related to the means of ship control, such as rudder angle and propeller rate of revolution. Their range should be selected taking into account the application domain. It is clear that a broad range of rates of revolutions of the propeller should be selected if engine manoeuvres are to be

simulated. For the simulation of standard manoeuvres, some rpm variation in the test runs may be considered in order to allow for variations of the rate of revolutions of the propeller that take place in a turning circle due to increased propeller loading.

### 2.2.3 Operational and analysis parameters

The third kind of parameters, related to the experimental or analysis technique, does not influence the model's kinematics, but may affect accuracy and validity of the test results (e.g. measuring time/length, number of harmonic cycles, waiting time between runs).

## 2.3 Execution of the Tests

### 2.3.1 Stationary straight-line tests

#### 2.3.1.1 Kinematics parameters

##### *Forward speeds*

The number of selected forward speeds depends on the purpose of the test program and the type of test. Table 2 reflects the actual practice, based on the response to the 1997 questionnaire (22<sup>nd</sup> ITTC Manoeuvring Committee, 1999).

##### *Drift angles*

In tests (a3) and (a4), the drift angle should be varied from zero to the maximum drift angle, which may be determined according to the purpose of the tests, at an appropriate interval.

The maximum drift angle should not exceed the one which causes interference of the model with the tank walls. Mean ranges appear to be  $[-20^\circ, +20^\circ]$  (a3) or  $[-15^\circ, +15^\circ]$  (a4);

drift angles exceeding  $\pm 35^\circ$  are only rarely applied.

	forward speeds				propeller loadings					
	cum. distr. (%)				max freq	cum. distr. (%)				max freq
	0	50	80	100		0	50	80	100	
a1	1	3	9	15	1	1	2	5	20	1
a2	1	2	4	6	1	1	1	5	10	1
a3	1	2	3	9	1	1	1	5	10	1
a4	1	1	3	5	1	1	1	8	10	1

	drift angles					rudder angles				
	cum. distr. (%)				max freq	cum. distr. (%)				max freq
	0	50	80	100		0	50	80	100	
a2	-	-	-	-	-	2	10	15	17	9
a3	3	11	15	23	12	-	-	-	-	-
a4	3	8	14	20	5	2	8	14	20	10

Table 2. Tests type (a): number of tests parameters

The applied range is not necessarily symmetric to zero drift. In test (a4), drift angles to both port and starboard should be tested to check for possible propeller induced asymmetry effects.

### 2.3.1.2 Ship control parameters

#### *Propeller rates of revolutions*

Most tests should be carried out at the (model or ship) self-propulsion point. Especially for straight towing tests without rudder action (a1) and rudder force tests (a2), other propeller loadings should be applied as well.

#### *Rudder angles*

In tests (a2) and (a4), the rudder(s) should be deflected from a maximum rudder angle in

one direction, to at least  $5^\circ$  in the other direction, so that the rudder angle resulting into zero lateral force and yawing moment can be determined. The maximum rudder angle should be determined according to the purpose of the tests, and in most cases coincides with “hard over”, although a lower deflection could be sufficient for some purposes. Rudder angles should be varied at appropriate intervals.

### 2.3.1.3 Operational and analysis parameters

Typically, a run consists of an acceleration phase, one or more stationary conditions, and a deceleration phase. Each stationary phase can be subdivided in a settling phase and a steady phase. Typical values for these phases, expressed as the non-dimensional distance covered by the ship model, are given in Table 3. Mostly, no distinction is made between the different types of stationary tests, although the length of the steady phase may influence the accuracy of analysis results; in this respect, Vantorre (1992) considers a measuring length of three times the ship model length as a minimum.

	cumul. distr. $P$ (%)				max freq
	0	50	80	100	
acceleration ( $L$ )	0.07	1.7	5.5	33.3	0.8
settling ( $L$ )	0.10	2.2	5.5	13.3	1.5
steady ( $L$ )	0.30	8.7	17.2	80.0	3.5
deceleration ( $L$ )	0.07	1.7	5.3	20.0	0.7
waiting time (min)	15	15	20	20	15

Table 3: Stationary straight-line tests (a): experimental parameters

 INTERNATIONAL TOWING TANK CONFERENCE	<b>ITTC – Recommended Procedures and Guidelines</b>	<b>7.5 - 02 06 - 02.2</b> Page 7 of 27	
	<b>Testing and Extrapolation Methods Manoeuvrability Captive Model Test Procedures</b>	Effective Date 2005	Revision 02

### 2.3.2 Harmonic tests

The number of parameters determining a PMM test is larger than in the case of a stationary test (see 2.1.3); furthermore, the parameters cannot always be chosen independently, or the choice may be restricted by the concept of the mechanism or the tank dimensions.

#### 2.3.2.1 Kinematic parameters

##### *Forward speed*

Forward speed should be selected according to the application domain. For a large range of applications, only one forward speed value is selected (see Table 1).

##### *Sway and yaw characteristics*

In principle, the application domain should also be taken into account for selecting sway and yaw characteristics. On the other hand, possible selections are limited by mechanism and tank characteristics. For harmonic sway tests (b1), amplitudes of lateral velocity and acceleration can be written non-dimensionally as follows:

$$\begin{aligned} v'_A &= y'_{0A} \omega'_1 \\ \dot{v}'_A &= y'_{0A} \omega'^2_1 \end{aligned} \quad (1)$$

while for yaw tests (b2), the following approximation can be made for small and moderate amplitudes:

$$\begin{aligned} r'_A &= \psi_A \omega'_1 \approx y'_{0A} \omega'^2_1 \\ \dot{r}'_A &= \dot{\psi}_A \omega'^2_1 \approx y'_{0A} \omega'^3_1 \end{aligned} \quad (2)$$

which implies that the range of non-dimensional sway and yaw kinematical parameters depend on:

- the non-dimensional lateral amplitude  $y'_{0A} = y_{0A}/L$ , and
- the non-dimensional circular frequency  $\omega'_1 = L/u$ , which are both subject to restrictions.

The lateral amplitude may be restricted due to limitations of the mechanism or, if not, should be selected to be less than the one which causes interference of the model with the tank walls. With respect to the latter, half the tank width may be considered as an upper limit for the trajectory width (van Leeuwen, 1964).

Limitations for the PMM test frequency  $\omega$  will be discussed in the paragraph “operational and analysis parameters”

##### *Drift angle*

The range of the drift angles  $\beta$  to be applied in test type (b4) has to be selected according to the application domain. The mean range appears to be  $[0^\circ, +16^\circ]$ .

#### 2.3.2.2 Ship control parameters

##### *Propeller rates of revolution*

Tests should usually be carried out at the self-propulsion point of model or ship, the latter requiring viscous correction.

##### *Rudder deflection*

The range of rudder angles  $\delta$  to be applied in test type (b3) has to be selected according to the application domain. The mean range appears to be  $[-20^\circ, +30^\circ]$ .

 INTERNATIONAL TOWING TANK CONFERENCE	<b>ITTC – Recommended Procedures and Guidelines</b>	<b>7.5 - 02</b> <b>06 - 02.2</b> Page 8 of 27	
	<b>Testing and Extrapolation Methods</b> <b>Manoeuvrability</b> <b>Captive Model Test Procedures</b>	Effective Date 2005	Revision 02

### 2.3.2.3 Operational and analysis parameters

#### Oscillation frequency

Restrictions of the oscillation frequency are usually expressed in a non-dimensional way, using one of following formulations:

$$\begin{aligned} \omega'_1 &= \frac{\omega L}{u} \\ \omega'_2 &= \omega \sqrt{\frac{L}{g}} = \omega'_1 Fr \quad (3) \\ \omega'_3 &= \frac{\omega u}{g} = \omega'_1 Fr^2 \end{aligned}$$

Restrictions of  $\omega'_1$  can be interpreted as follows.

- Restrictions due to tank length: the number of oscillation cycles  $c$  is limited by:

$$c \leq \frac{1}{2\pi} \frac{L_{\text{tank}}}{L} \omega'_1 \quad (4)$$

$L_{\text{tank}}$  being the available tank length

- Avoiding non-stationary lift and memory effects yields a maximum  $\omega'_1$  (Nomoto, 1975; Wagner Smitt & Chislett, 1974; Milanov, 1984; van Leeuwen, 1969), typically 1-2 for sway and 2-3 for yaw tests. Comparable values result from considerations on lateral wake patterns (Vantorre & Elout, 1997).
- Considerations on the influence of errors of the imposed trajectory on the accuracy of the hydrodynamic derivatives lead to compromise values for  $\omega'_1$  which are in the range mentioned above for yaw tests (2-4), but which are very low (0.25-2) for sway tests. It is therefore recommended to derive sway velocity derivatives from oblique towing tests, so that the accuracy of the in-

ertia terms can be improved by increasing the test frequency (Vantorre, 1992; see also 4.2).

Restrictions for  $\omega'_2$  can be interpreted as measures for avoiding tank resonance. If the PMM frequency equals one of the natural frequencies of the water in the tank, a standing wave system may interfere with the tests. This occurs if the wavelength  $\lambda$  of the wave system induced by the oscillation equals  $2b/n$  ( $n = 1, 2, \dots$ ),  $b$  being the tank width. Fehler! Verweisquelle konnte nicht gefunden werden. displays the frequency fulfilling  $\lambda = 2b$  as a function of water depth and tank width; in case of infinite depth, tank resonance occurs at  $\omega_2'^2 = \pi L/b$ .

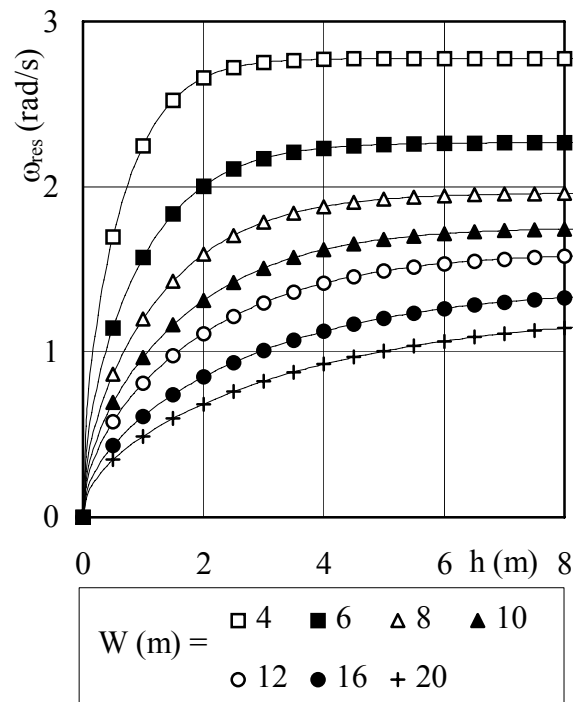

Figure 2: Lowest tank resonance frequency as a function of water depth  $h$  for several tank width values  $b$ .

Restrictions for  $\omega_3'$  are imposed for avoiding unrealistic combinations of pulsation and translation. The nature of a wave system induced by a pulsating source with a frequency, moving at constant speed  $u$  in a free surface strongly depends on  $\omega_3'$ , 0.25 being a critical value (Brard, 1948; Wehausen & Laitone, 1960; van Leeuwen, 1964). Therefore,  $\omega_3'$  should be considerably less than 0.25 during PMM tests (van Leeuwen, 1964; Goodman et al, 1976; Wagner Smitt & Chislett, 1974), as illustrated in Figure 2.

Furthermore, the circular oscillation frequency must not be selected near to a natural frequency of the carriage or measuring equipment.

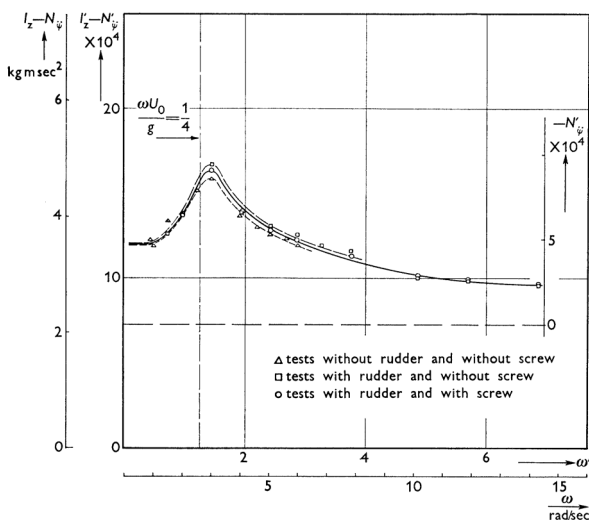

Figure 3: Influence of  $\omega_3'$  on added moment of inertia from PMM yaw tests (van Leeuwen, 1964)

Table 4 summarises actual practice concerning the selection of test frequencies expressed in a non-dimensional way. (3) reveals

that limitations of  $\omega_1'$  will be overruled by those of  $\omega_2'$  and  $\omega_3'$  for larger Froude numbers.

	max.freq	$P=50\%$	$P=80\%$	empiric
$\omega_1'$	0.5 - 1.5	5.0	14	1 - 4
$\omega_2'$	0.1 - 0.2	0.5	0.9	0.15-0.2
$\omega_3'$	0.02- 0.04	0.08	0.22	$\ll 0.25$

Table 4: Harmonic tests (b): frequency selection

*Number of oscillation cycles.*

The number of oscillations should be determined to be large enough to obtain periodic results, noting that the transient starting and stopping regions should not be used in the analysis. The reliability of the test results increases with the number of cycles  $c$ , although this effect is rather restricted if  $c > 3$  (Vantorre, 1992). Common practice concerning the number of cycles considered for analysis is given in Table 5, which also gives an indication about the number of cycles skipped in order to obtain a steady state.

	$P = 50\%$	$P = 80\%$	max. freq.
transient	1 cycle	3 cycles	1 cycle
steady	2 cycles	4 cycles	2 cycles

Table 5: Harmonic tests (b): experimental parameters.

	<b>ITTC – Recommended Procedures and Guidelines</b>	<b>7.5 - 02 06 - 02.2</b> Page 10 of 27	
	<b>Testing and Extrapolation Methods Manoeuvrability Captive Model Test Procedures</b>	Effective Date 2005	Revision 02

### 2.3.3 Stationary circular tests

#### 2.3.3.1 Kinematics parameters

##### *Forward speeds*

The number of selected forward speeds is the same for tests (c1), (c2), (c3), (c4) as for tests type (a2), (a3), (a4). When dealing with large yaw rates, the speed loss of the manoeuvring ship can be considered to determine the test speed range.

##### *Yaw rate*

Based on actual practice reported by the 1997 questionnaire (22<sup>nd</sup> ITTC Manoeuvring Committee, 1999), non-dimensional yaw rate values  $r'$  for circular motion tests vary from 0.07 to 1; median range being between 0.20 and 0.75.

##### *Drift angles*

Experience shows that there is a close relationship between drift angle and non dimensional yaw rate for a free running manoeuvring ship (Figure 4 proposes a typical sketch of the envelope of yaw rate and drift for a ship during large zigzag tests).

It is therefore not necessary to choose a range of drift angles symmetric to zero. For a given value  $r'$  of the non-dimensional rate of turn, a midrange value of drift angle ( $^{\circ}$ )  $\beta = 26.r'$  can be considered as a rough figure.

The maximum drift angle should not exceed the one which causes interference of the model with the tank walls.

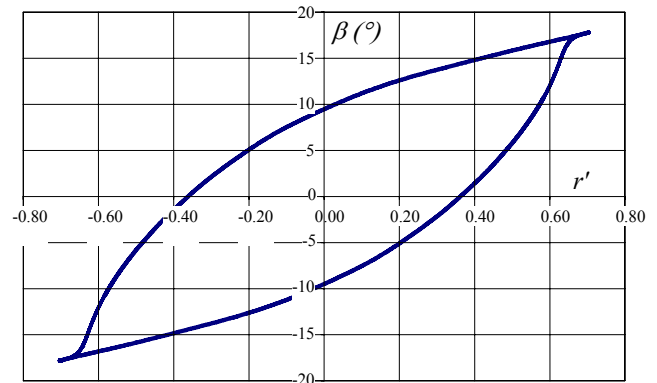

Figure 4: Yaw rate, drift angle envelope for a surface ship

#### 2.3.3.1 Ship control parameters

##### *Propeller rates of revolutions.*

As for straight towing tests, tests should be carried out at the (model or ship) self-propulsion point. Especially for straight towing tests without rudder action (a1) and rudder force tests (a2), other propeller loadings should be applied as well.

##### *Rudder angles*

During yaw, drift and rudder deflection tests (c4), rudder angle range should be defined to cover the actual range of rudder angle for a given rate of turn of the rudder. Rudder angles should be varied at an appropriate interval.

#### 2.3.3.1 Operational and analysis parameters

Typically, a run consists of an acceleration phase, a stationary condition, and a deceleration phase. For rotating arm tests there is no limitation for the deceleration, but the stationary phase should be limited in order to avoid that the model runs in its own wake after a

complete turn. Figure 5 illustrates the influence of speed and radius of turn for a given ship on the “available” stationary conditions in a single turn.

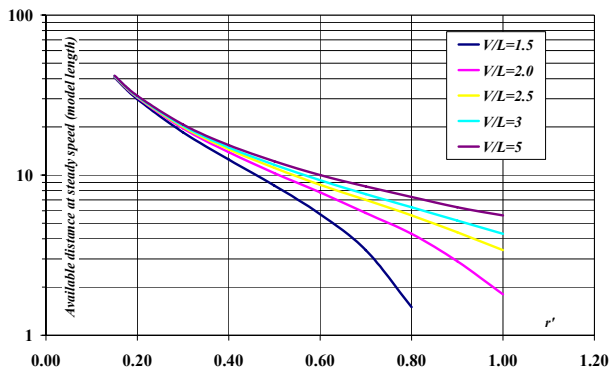

Figure 5: Influence of speed and  $r'$  on duration of stationary conditions (ship length) for a complete turn

## 2.4 Data acquisition and analysis

### 2.4.1 Measured data

Performing captive manoeuvring tests requires direct or indirect measurement of following data:

- longitudinal hull force,
- lateral hull force,
- hull yawing moment,

together with, - at least for particular purposes:

- rolling moment.

The measurement of parameters characterising the control of ship model steering and propulsion equipment is convenient:

- rudder angle,
- propeller rpm,
- other steering/manoeuvring devices' action.

Measurement of position/speed of the driving mechanism results in useful information on the actual trajectory of the model.

- trajectory,
- speed.

Following data may be important, depending on the mathematical manoeuvring model:

- thrust/torque on propeller (s),
- forces and moments on rudder(s),

While the motion of the ship model according to the non-constrained degrees of freedom (sinkage, trim, in particular cases roll angle) may be useful for other purposes.

The capacity of load cells and other measuring equipment should be chosen to be appropriate to the loads expected. Calibration of sensors and driving units should be carried out immediately before and immediately after testing.

### 2.4.2 Data acquisition

Data sampling rate and filtering details should be determined on the basis of the oscillation frequency, together with considerations of the primary noise frequencies. Sampling rates may vary between 4 and 250 Hz, 20 Hz being a mean value.

The measured real time data should be recorded. It is recommended that real-time analysis be made immediately after each tests in order to check for obvious errors in the data.

### 2.4.3 Visual inspection

After each run the data should be inspected in the time domain to check for obvious errors such as transients caused by recording too soon after starting, additional unknown sources of

	<b>ITTC – Recommended Procedures and Guidelines</b>	<b>7.5 - 02 06 - 02.2</b> Page 12 of 27	
	<b>Testing and Extrapolation Methods Manoeuvrability Captive Model Test Procedures</b>	Effective Date 2005	Revision 02

noise, overloading or failure of one or more sensors. Transients due to starting, stopping or changing conditions should not be included in the data to be analysed.

#### 2.4.4 Analysis methods

For stationary tests (a, c), a mean value of the measured data should be calculated over the time interval in which results are stationary. Analysis of harmonic tests (b) requires techniques such as Fourier analysis, regression analysis, system identification.

#### 2.4.5 Analysis of forces

Detailed analysis should be carried out using the stored data. This can be performed after all the tests have been finished. The hydrodynamic coefficients should be obtained on the basis of the mathematical model to be utilised for manoeuvring simulations.

While many different possible analysis methods exist, the following procedures may generally be employed.

For hull forces:

- resistance and propulsion data from (a1);
- coefficients for sway velocity from (a3);
- coefficients for yaw rate from (b2) or (c1);
- coefficients for sway velocity and yaw rate from (b4) or (c2);
- inertia coefficients from (b1) and (b2).

The frequency dependence of hydrodynamic forces should be checked, and it should be ensured that the coefficients are equivalent to those at zero frequency. Where possible this can be done by comparison with stationary tests.

For rudder forces, e.g.:

- coefficients of the forces induced on a ship hull due to rudder deflection from (a2);
- coefficients expressing the effect of lateral motion of the stern on rudder induced forces from (a4), (b3) and/or (c3), (c3).

## 2.5 Prediction procedure

The simulation of ship manoeuvring motion may generally be performed by applying the mathematical model with which the test results are analysed, making use of the hydrodynamic coefficients obtained through the process described above.

## 2.6 Documentation

The following should, but not restrictively, be documented and included in the test report.

### 2.6.1 Experimental technique

#### 2.6.1.1 Model

##### *General characteristics*

The following characteristics must be specified:

- main particulars of the ship:
  - length between perpendiculars,
  - beam;
- scale of the model;
- moment of inertia in yaw;
- moment of inertia in roll (if roll motion is not restrained);
- engine type for the full-scale ship.

	<b>ITTC – Recommended Procedures and Guidelines</b>	<b>7.5 - 02 06 - 02.2</b> Page 13 of 27	
	<b>Testing and Extrapolation Methods Manoeuvrability Captive Model Test Procedures</b>	Effective Date 2005	Revision 02

### The hull

Following hull data should be included in the documentation:

- the loading condition, to be specified as draught at AP and draught at FP or, alternatively, as mean draught amidships and trim or trim angle;
- a set of hydrostatic data for the tested loading condition, including, as a minimum:
  - displacement,
  - longitudinal centre of buoyancy (LCB) /gravity (LCG) when different (heave constrained model)
  - in case roll motion is free: KB, KG and BM values;
- also preferably a full set of hydrostatic data should be included;
- a body plan and stern and stem contour of the model;
- description and drawing of appendages on the hull (bilge keels, additional fins, etc.);
- any turbulence stimulation;
- photographs of the model, stern and stem equipped with all appendages.

### The rudder

It should be specified whether the rudder is custom made as on the real ship or a stock rudder. In the case of a stock rudder, both the stock rudder and the full-scale rudder should be documented as specified:

- rudder type (spade, horn, flap, etc.);
- rudder drawing including contour, profiles and possible end-plates;
- specification of movable area  $A_{RF}$  and fixed area  $A_{RX}$ ;
- rudder rate of turning.

### The propeller

It should be specified whether the propeller is custom made as on the real ship or a stock propeller is used. In the case of a stock propeller both propellers should be documented equally well as specified:

- propeller diameter  $D$ ;
- propeller type, FP or CP;
- number of propeller blades  $Z$ ;
- propeller pitch ratio  $p$  ( $P/D$ );
- propeller area ratio  $A_E/A_0$ ;
- propeller hub position;
- open water curves showing  $K_T$  and  $K_Q$ .

#### 2.6.1.2 Tank

Following tank characteristics should be specified:

- dimensions;
- water depth;
- depth to draft ratio;
- water temperature.

In addition for shallow water tests

- bottom flatness

#### 2.6.1.3 Model set-up

It should be stated whether the tests are performed as:

- bare hull plus appended hull tests, or
- appended hull tests alone.

The number of degrees of freedom (model restraints for heave, pitch and roll modes) should be stated. If applicable, details of forced roll should be included.

It should be stated whether engine simulation is used. If yes, the principle for the method should be described.

	<b>ITTC – Recommended Procedures and Guidelines</b>	<b>7.5 - 02 06 - 02.2</b> Page 14 of 27	
	<b>Testing and Extrapolation Methods Manoeuvrability Captive Model Test Procedures</b>	Effective Date 2005	Revision 02

It should be stated how scale effects are accounted for. For appended hull tests, the type and amount of friction deduction force applied.

#### 2.6.1.4 Measurements, recording, calibration

The documentation should contain the main characteristics of:

- measuring equipment;
- load cells;
- filters.

A complete list of channels measured during the tests should be provided, including:

- sample time;
- digitising rate.

Details of all calibrations conducted should be provided, including information on linearity and repeatability of all sensors.

#### 2.6.1.5 Test parameters

A complete list of the runs performed for each type of test should be given. The list should at least include:

- test type;
- model speed;
- time of stationary test;
- number of cycles in oscillatory tests;
- oscillation frequency, with proof of avoidance of resonance with natural frequencies of the mechanism, the measuring equipment and the water in the tank;
- drift angle;
- rudder angle;
- yaw rate;
- lateral amplitude;
- propeller rpm;
- other parameters.

#### 2.6.2 Analysis procedure

The analysis covers the process of transferring the measured raw data into the mathematical manoeuvring model. This is a difficult process and the procedure is different for every towing tank.

Following items should be included in the documentation:

- method of force analysis;
- force coefficients, together with the mathematical model used for analysis of measured data;
- number of cycles used for analysis of oscillatory tests;
- oscillation frequency indicating the equivalence of the coefficients to those at zero frequency;
- filtering technique;
- basic principles for fairing the data;
- plots of measured points together with the faired curves for all tested parameters in the whole range, which should include the expected range for the manoeuvres to be predicted.

### 3. PARAMETERS

#### 3.1 Parameters to be taken into account

##### 3.1.1 General

Following parameters should be taken into account for all captive model tests:

- scale
- model dimensions
- ratios of model to tank dimensions water depth
- hull configuration (hull, rudder, propeller)
- model mass
- position of centre of gravity of ship model

	<b>ITTC – Recommended Procedures and Guidelines</b>	<b>7.5 - 02 06 - 02.2</b> Page 15 of 27	
	<b>Testing and Extrapolation Methods Manoeuvrability Captive Model Test Procedures</b>	Effective Date 2005	Revision 02

- moments of inertia of ship model
- degrees of freedom
- loading condition of ship model

### 3.1.2 Stationary straight line tests

Following parameters should especially be taken into account for tests of type (a):

- number of conditions
- forward speed(s)  $u$
- range of drift angles  $\beta$  (a3, a4 only)
- propeller rate(s)  $n$
- range of rudder angles  $\delta$  (a2, a4 only)
- time/distance required for acceleration, settling, steady phase, deceleration

### 3.1.3 Harmonic tests

Following parameters should especially be taken into account for tests of type (c):

- forward speed(s)  $u$
- amplitudes of sway/yaw motion ( $v_{0A}, r_A$ ) and, thereby, of velocity ( $v_A, r_A$ ) and acceleration ( $\dot{v}_A, \dot{r}_A$ );
- range of drift angles  $\beta$  (b4 only);
- propeller rate(s)  $n$ ;
- range of rudder angles  $\delta$  (b3 only);
- circular frequency  $\omega$  or period  $T$  of oscillation;
- number of cycles  $c$ .

### 3.1.4 Stationary circular tests

Following parameters should especially be taken into account for tests of type (c):

- number of conditions
- forward speed(s)  $u$
- non dimensional rate of turn  $r'$
- range of drift angles  $\beta$  (c2, c4 only)
- propeller rate(s)  $n$
- range of rudder angles  $\delta$  (c3, c4 only)

- time/distance required for acceleration, settling, steady phase, deceleration.

## 4. VALIDATION

### 4.1 Causes of uncertainty

During captive manoeuvring tests, a ship model is forced by an external mechanism to undergo a prescribed trajectory in the horizontal plane. The measurement of forces acting on the model leads to the numerical value of a number of characteristic coefficients occurring in the mathematical manoeuvring model, which can be used for predicting various aspects of manoeuvring behaviour, including standard manoeuvres.

The accuracy of test results is influenced by imperfections of the experimental technique. Following types may be distinguished:

#### 4.1.1 Imperfections causing errors to the boundary and/or initial conditions

##### 4.1.1.1 Inaccuracy of ship model characteristics

The influence of some factors (e.g. errors on main dimensions, offsets, loading condition) on the accuracy of test results is hard to estimate, while variations of other parameters (e.g. mass, moments of inertia) have a rather straightforward effect on the forces acting on the model.

##### 4.1.1.2 Undesired facility related hydrodynamic effects

A ship model's dynamics and, therefore, test results may be affected by several influences caused by the limitations of the experi-

	<b>ITTC – Recommended Procedures and Guidelines</b>	<b>7.5 - 02 06 - 02.2</b> Page 16 of 27	
	<b>Testing and Extrapolation Methods Manoeuvrability Captive Model Test Procedures</b>	Effective Date 2005	Revision 02

mental facility, e.g. that tests are not performed in un-restricted still water. Some examples:

- Residual motion of the water in the tank may affect the model's dynamics if the waiting time between two runs is too short.
- Non-stationary phenomena occurring during transition between acceleration and steady phases or if harmonic techniques are applied may also affect the model's dynamics.
- Tank width and also length limitations induce undesired additional forces.
- In shallow water tests, bottom profile variations affect the model's dynamics.

The influence of these effects on the accuracy of test results generally increases with decreasing water depth. Although complete prevention is principally impossible, the effects can be reduced by an adequate selection of test and analysis parameters.

#### 4.1.2 Imperfections with direct or indirect influence on the ship model's dynamics

##### 4.1.2.1 Mechanism geometry discrepancies

The geometry of the mechanism and, therefore, the trajectory of the ship model may be influenced by elastic deformation, backlash and mechanical imperfections, causing geometrical errors  $g_{i(E)}$  which may affect model kinematics and dynamics.

A detailed analysis highly depends on the type and concept of the mechanism. Following factors may be of importance in the case of a PMM system with three degrees of freedom:

- deviations of the main carriage with respect to the tank:

- horizontal deviations of the main carriage's guiding rail;
- backlash between guiding rail and horizontal guiding wheels;
- accuracy of the guiding wheels (radius, eccentricity, backlash);
- vertical deviations of both rails;
- accuracy of the main carriage's wheels (radius, eccentricity, backlash);
- deviations of the lateral carriage with respect to the main carriage:
  - alignment of guiding for lateral carriage;
  - perpendicularity of guiding for lateral carriage with respect to main carriage;
  - backlash of guiding for lateral carriage;
- deviations of the rotation table with respect to the lateral carriage:
  - alignment of rotation axis;
  - verticality of guiding for yaw table;
  - backlash;
- deviations of the model connection system with respect to the rotation table;
- inaccuracies of the connection of the ship model to the mechanism

With respect to the latter, a distinction should be made between connection inaccuracies according to either the free or the forced motion modes. Captive model tests executed for investigation of manoeuvring of surface ships require forced surge, sway and yaw motions, while the model is usually free to heave and pitch. Roll motions may be free or forced.

- Some errors are caused by imperfections of the connection system:

	<b>ITTC – Recommended Procedures and Guidelines</b>	<b>7.5 - 02 06 - 02.2</b> Page 17 of 27	
	<b>Testing and Extrapolation Methods Manoeuvrability Captive Model Test Procedures</b>	Effective Date 2005	Revision 02

- geometry imperfections and backlash may cause position errors in all motion modes;
- mechanical friction between moving parts may result into position errors in the free motion modes;
- inaccurate mounting may induce position errors in all forced motions modes

but even a perfectly functioning connection may induce position errors in the forced modes due to motions in the free modes. Due to the concept of some connection systems, pitch and heave indeed induce a small surge component.

#### 4.1.2.2 Mechanism control and setting errors

The kinematics of the driving mechanism and, therefore, of the model are determined by a number of directly controllable parameters  $s_i$  which are either kept constant or controlled according to a time function during a test run. Setting and control errors  $s_i(E)$  on these parameters indirectly influence the forces acting on the model. An analysis of this influence strongly depends on the concept of the mechanism and the type of test.

Divergences between prescribed and actual trajectories can also be caused by inaccuracy of the measurement of position or speed of the (sub-)mechanisms, affecting the control system's feedback signal. Possible causes are:

- temperature influence;
- slip (of encoder wheel), backlash;
- errors/deformation in transmission to encoder;
- resolution of encoder.

Special attention should be paid to possible limitations of the mechanism concept, which

may not allow the execution of some from theoretical point of view desirable trajectories. For example, small amplitude PMM systems based on the combined action of two horizontal oscillators may not be able to perform a pure harmonic yaw motion. In other cases, limitations of the control system yield deviations from the theoretically desired trajectory: this is for instance the case if a PMM system is mounted on a towing carriage which is not equipped with a variable speed control, as this leads to fluctuations of the ship's forward speed component during a harmonic yaw test. Principally, such discrepancies are predictable and can be accounted for during analysis.

#### 4.1.2.3 Errors on ship control equipment parameters

During a test run, a number of control equipment parameters  $\mu_i$  (propeller rpm, rudder angle, ...) are controlled; setting or control errors have a direct influence on the forces acting on the model.

#### 4.1.3 Interpretation errors due to limitations of signal generation and manipulation

##### 4.1.3.1 Measurement accuracy

The quality of force measurements may be affected by non-linearity, hysteresis, sensitivity, accuracy of calibration, Errors on position and speed measurements not only affect the mechanism's control loop (see above), but also the interpretation of the measured forces.

##### 4.1.3.2 Data acquisition

Deformation of the measured signals may be induced by signal processing techniques,

 INTERNATIONAL TOWING TANK CONFERENCE	<b>ITTC – Recommended Procedures and Guidelines</b>	<b>7.5 - 02</b> <b>06 - 02.2</b> Page 18 of 27	
	<b>Testing and Extrapolation Methods</b> <b>Manoeuvrability</b> <b>Captive Model Test Procedures</b>	Effective Date 2005	Revision 02

due to characteristics of e.g. filters, AD-conversion (resolution, time step).

#### 4.1.3.3 Numerical analysis

The accuracy of calculated average values and harmonics appears to depend on test parameters (e.g. integration length, test frequency, number of cycles).

## 4.2 Uncertainty analysis

### 4.2.1 Trajectory

A ship model's trajectory is generated by the mechanism through *m' mechanism control and setting parameters  $s_i$* . Some examples:

#### 4.2.1.1 Computerized PMM with three degrees of freedom (Figure 6)

In case of a position controlled towing carriage, control parameters are: translations of longitudinal ( $s_1$ ) and lateral ( $s_2$ ) carriages, and rotation of yawing table ( $s_3$ ):

$$\mathbf{x}_0 = [s_1; s_2; s_3]^T \quad (5)$$

In the case of a speed controlled carriage,  $s_1$  is the towing carriage speed, and (5) is replaced by:

$$\mathbf{x}_0 = \left[ x_0 + \int_0^t s_1(t) dt; s_2; s_3 \right]^T \quad (6)$$

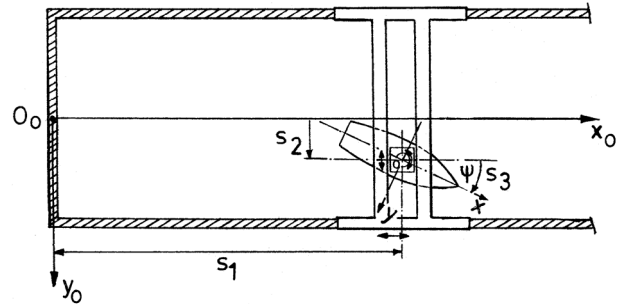

Figure 6: Computerized PMM with three degrees of freedom (position controlled).

#### 4.2.1.2 Large Amplitude PMM System of the DMI type (Figure 7)

Control parameters are: towing carriage position  $s_1$  (in case of a position controlled towing carriage), sway crank length  $s_2$ , yaw crank length  $s_3$ , angular position of sway crank  $s_4$ , static drift angle  $s_5$ :

$$\mathbf{x}_0 = \left[ s_1; 2s_2 \sin s_4; s_5 + \arctan \left( \frac{s_3}{R} \cos s_4 \right) \right]^T \quad (7)$$

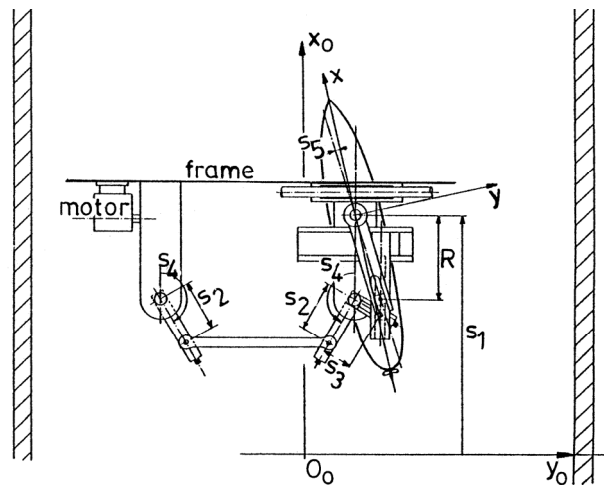



Figure 7: Large Amplitude PMM System (DMI type).

 INTERNATIONAL TOWING TANK CONFERENCE	<b>ITTC – Recommended Procedures and Guidelines</b>	<b>7.5 - 02 06 - 02.2</b> Page 19 of 27	
	<b>Testing and Extrapolation Methods Manoeuvrability Captive Model Test Procedures</b>	Effective Date 2005	Revision 02

#### 4.2.1.3 Rotating arm basin

Control parameters are the radius  $s_1$ , the angular position of the arm  $s_2$  and the drift angle  $s_3$ :

$$[\mathbf{x}_0] = \left[ s_1 \cos s_2; s_1 \sin s_2; \frac{\pi}{2} + s_2 + s_3 \right]^T \quad (8)$$

Reference values are marked by  $^{(0)}$ :

$$[\mathbf{x}_0^{(0)}] \equiv \begin{bmatrix} x_0^{(0)} \\ y_0^{(0)} \\ \psi^{(0)} \end{bmatrix} = [\mathbf{x}_0(s_1^{(0)}, \dots, s_m^{(0)})] \quad (9)$$

The actual trajectory will differ from its reference due to control errors  $s_i^{(E)}(t)$  causing divergences of the actual time history  $s_i(t)$  of the control parameters from the prescribed  $s_i^{(0)}(t)$ :

$$s_i(t) = s_i^{(0)}(t) + s_i^{(E)}(t) \quad (10)$$

and  $m$  mechanism geometry discrepancies  $g_i^{(E)}$ .

The actual path can therefore be written as

$$\begin{aligned} [\mathbf{x}_0] &= [\mathbf{x}_0(s_1, \dots, s_m, g_1, \dots, g_m)] \\ &= [\mathbf{x}_0(\sigma_1, \dots, \sigma_m)] \end{aligned} \quad (11)$$

where  $\sigma_i, \dots, \sigma_m$  can be considered as (*directly controllable*) mechanism parameters.

The actual trajectory is developed in a Taylor series about its reference,  $^{(n)}$  denoting  $n$ -th order terms in the mechanism parameter errors:

$$\begin{aligned} [\mathbf{x}_0] &= [\mathbf{x}_0^{(0)}] + [\mathbf{x}_0^{(E)}] = [\mathbf{x}_0^{(0)}] + \sum_{n=1}^{\infty} [\mathbf{x}_0^{(n)}] \\ &= [\mathbf{x}_0^{(0)}] + \sum_{n=1}^{\infty} \frac{1}{n!} \left( \sum_{j=1}^m \sigma_j^{(E)} \frac{\partial}{\partial \sigma_j} \right)^n [\mathbf{x}_0^{(0)}] \end{aligned} \quad (12)$$

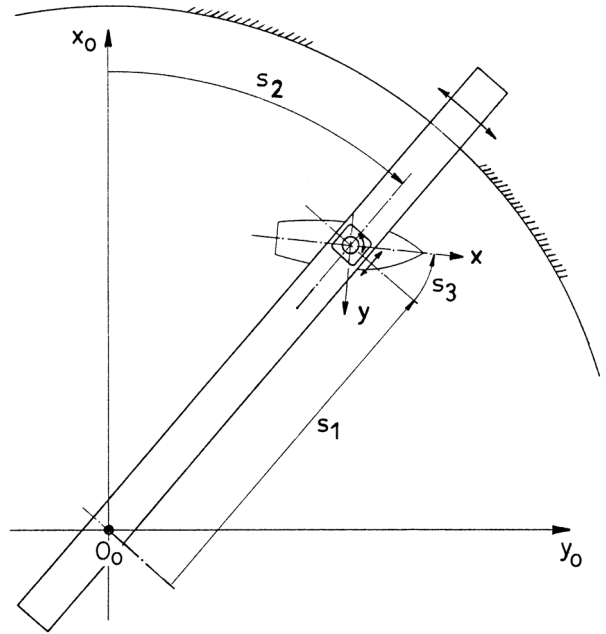



Figure 8: Rotating arm

#### 4.2.2 Kinematics

Time derivation of (11) and transformation to the ship coordinate system yields expressions for the actual velocity and acceleration components. If only first order terms in  $\sigma^{(E)}$  and their time derivatives are taken into account, a linear relationship can be formulated by means of *kinematic influence matrices*  $K$ :

 INTERNATIONAL TOWING TANK CONFERENCE	<b>ITTC – Recommended Procedures and Guidelines</b>	<b>7.5 - 02 06 - 02.2</b> Page 20 of 27	
	<b>Testing and Extrapolation Methods Manoeuvrability Captive Model Test Procedures</b>	Effective Date 2005	Revision 02

$$\begin{aligned}
[u^{(E)}] &\approx [u^{(1)}] = \|K_{u,\dot{\sigma}}^{(1)}\| [\dot{\sigma}^{(E)}] + \|K_{u,\sigma}^{(1)}\| [\sigma^{(E)}] \\
[\dot{u}^{(E)}] &\approx [\dot{u}^{(1)}] = \|K_{\dot{u},\ddot{\sigma}}^{(1)}\| [\ddot{\sigma}^{(E)}] + \|K_{\dot{u},\dot{\sigma}}^{(1)}\| [\dot{\sigma}^{(E)}] \\
&\quad + \|K_{\dot{u},\sigma}^{(1)}\| [\sigma^{(E)}] \quad (13)
\end{aligned}$$

#### 4.2.3 Dynamics

A mathematical manoeuvring model formulates forces and moments acting on a ship (model) as functions of  $p$  variables:

$$[X] \equiv \begin{bmatrix} X \\ Y \\ N \end{bmatrix} = \begin{bmatrix} X(c_1, \dots, c_p) \\ Y(c_1, \dots, c_p) \\ N(c_1, \dots, c_p) \end{bmatrix} \quad (14)$$

The *mathematical manoeuvring model parameters*  $c_j$  are related to the ship model's kinematics and its control equipment:

$$[c] = \begin{bmatrix} c_1 \\ \dots \\ c_p \end{bmatrix} = [u \quad v \quad r \quad \dot{u} \quad \dot{v} \quad \dot{r} \quad \mu_1 \quad \dots \quad \mu_p]^T \quad (15)$$

where  $\mu_j$  denote *ship model control equipment parameters* (e.g. propeller rate, rudder angle).

Deviations  $[c(E)(t)]$  between the actual time history  $[c(t)]$  and the theoretical time history  $[c(0)(t)]$  of these variables lead to differences  $[X(E)(t)]$  between actual  $[X(t)]$  and expected forces  $[X(0)(t)]$ . If analytical expressions exist for (13), the actual force can be written as:

$$\begin{aligned}
[X] &= [X^{(0)}] + [X^{(E)}] = [X^{(0)}] + \sum_{n=1}^{\infty} [X]^{(n)} \\
&= [X^{(0)}] + \sum_{n=1}^{\infty} \frac{1}{n!} \left( \sum_{j=1}^p c_j^{(E)} \frac{\partial}{\partial c_j} \right)^n [X^{(0)}] \quad (16)
\end{aligned}$$

$\langle n \rangle$  denoting  $n$ -th order terms in  $c_j(E)$

During captive tests, some parameters  $c_j$  are directly controllable; this is usually the case for the ship model control equipment parameters  $\mu_1, \dots, \mu_p$ . The kinematical parameters, on the other hand, are induced by the mechanism and are therefore indirectly controlled through the mechanism parameters  $c_i$ .

Introducing (12) in (15) yields expressions for the ship model's dynamics as a function of directly controllable parameters ( $c_j, \mu$ ) only. If only first order terms in these errors are considered, the error on the force can be formulated by means of dynamic influence matrices  $D$ :

$$\begin{aligned}
[X^{(E)}] &\approx [X^{(1)}] \\
&= \|D_{\dot{\sigma}}^{(1)}\| [\dot{\sigma}^{(E)}] + \|D_{\sigma}^{(1)}\| [\sigma^{(E)}] \\
&\quad + \|D_{\mu}^{(1)}\| [\mu^{(E)}] + \|D_{\mu}^{(1)}\| [\mu^{(E)}] \quad (17)
\end{aligned}$$

#### Data acquisition

The forces acting on the force transducers induce analog signals which may be filtered, amplified, and converted in a digital format. Errors due to data acquisition techniques (see 4.1.3) are not considered here.

#### 4.2.4 Numerical analysis

Measured force signals are converted into experimental results by calculating averages in case of stationary tests:

$$[X]^{[0]} = \frac{1}{T} \int_0^T [X(t)] dt \quad (18)$$

 INTERNATIONAL TOWING TANK CONFERENCE	<b>ITTC – Recommended Procedures and Guidelines</b>	<b>7.5 - 02</b> <b>06 - 02.2</b> Page 21 of 27	
	<b>Testing and Extrapolation Methods</b> <b>Manoeuvrability</b> <b>Captive Model Test Procedures</b>	Effective Date 2005	Revision 02

Registered data from non-stationary (e.g. periodic) tests may be processed in different ways, e.g. by applying Fourier analysis:

$$[\mathbf{X}(t)] = \text{Re} \left\{ \sum_{n=0}^{\infty} [\tilde{X}]^{[n]} e^{-in\omega t} \right\} \quad (19)$$

a superscript  $^{[n]}$  denoting the n-th harmonic:

$$[\tilde{X}]^{[n]} = \frac{2q_n}{cT} \begin{pmatrix} \int_{t_k^{[n]}}^{cT+t_k^{[n]}} [X(t)] \cos n\omega t dt \\ + i \int_{t_k^{[n]}}^{cT+t_k^{[n]}} [X(t)] \sin n\omega t dt \end{pmatrix} \quad (20)$$

$$= \frac{q_n}{\pi c} \int_{\varepsilon^{[n]}}^{2\pi c + \varepsilon^{[n]}} [X(t)] e^{in\omega t} d\omega t$$

$$\text{with} \begin{cases} q_0 = \frac{1}{2} \\ q_1 = q_2 = \dots = 1 \end{cases}$$

$c$  being the number of analysed cycles. The integration phase angle  $\varepsilon^{[n]}$  may be different for the sine and the cosine components.

Stationary tests can be considered as a special case of harmonic tests; for stationary tests,  $\omega = 2\pi/T$ ,  $T$  being the steady measuring phase.

The influence of fluctuations of the directly controllable parameters ( $s$ ,  $g$ ,  $\mu$ ) on the force harmonics is assessed considering a harmonic fluctuation with amplitude  $s_A^{(E)}$ , pulsation  $\omega$  and phase angle  $\phi$ :

$$[s^{(E)}(t)] = [s_A^{(E)}] \cos(\alpha\omega t + \phi) \quad (21)$$

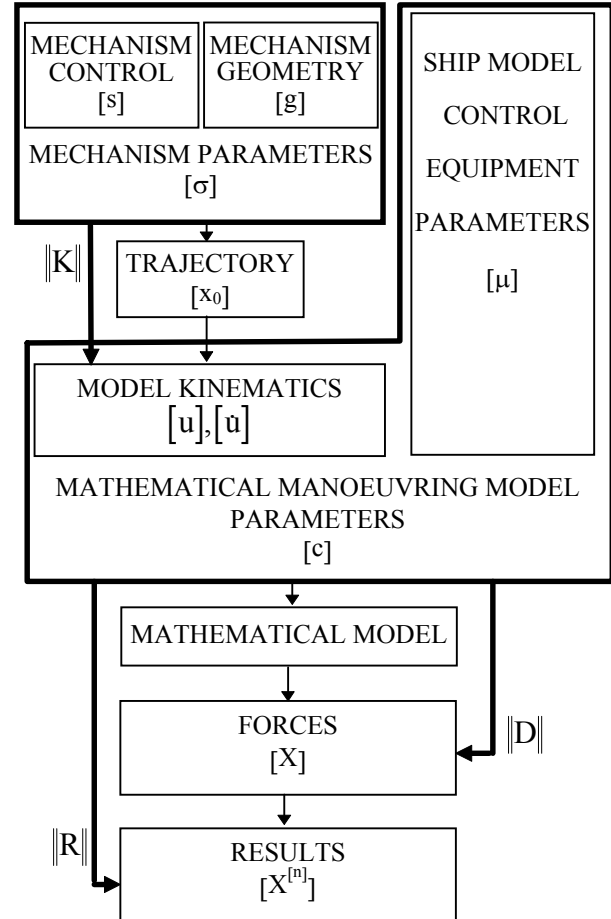



Figure 9: Overview of factors influencing accuracy of test results.

The error on the  $n$ -th force harmonic caused by such a fluctuation is presented by:

$$[\tilde{X}^{(1)}]^{[n]} = \frac{q_n}{c\pi} \int_{\varepsilon^{[n]}}^{2c\pi + \varepsilon^{[n]}} [X^{(1)}(t)] e^{in\omega t} d\omega t \quad (22)$$

$$= \|\tilde{r}_{s,\alpha\omega}^{(1)}\|^{[n]} [s_A^{(E)}]$$

in which the matrix  $[r]$  contains the phase angle  $\phi$ . The upper limit of the error on the  $n$ -th force harmonic, which occurs at a specific phase an-

 INTERNATIONAL TOWING TANK CONFERENCE	<b>ITTC – Recommended Procedures and Guidelines</b>	<b>7.5 - 02 06 - 02.2</b> Page 22 of 27	
	<b>Testing and Extrapolation Methods Manoeuvrability Captive Model Test Procedures</b>	Effective Date 2005	Revision 02

gle, is stored in a *results influence matrix* denoted  $[R]$ , which is a function of the fluctuation frequency  $\alpha\omega$ , but may also depend on integration parameters (e.g.  $\mathcal{E}^n$ ):

$$\|\tilde{R}_{s,\alpha\omega}^{(1)}\|^{[n]} = \max_{\phi} \|\tilde{r}_{s,\alpha\omega}^{(1)}\|^{[n]} \quad (23)$$

Because of the size and complexity of these influence matrices, only a few representative examples are discussed; see Vantorre (1988, 1990, 1992) for a full theoretical treatment. A schematic representation of all influencing factors is given in Figure 9.

#### 4.2.5 Influence of ship model's dynamics on forces and moments

##### 4.2.5.1 Example 1: oblique towing - influence of carriage speed fluctuations on lateral force.

Following mathematical model is used for the lateral hull force:

$$\begin{aligned} Y &= (Y_{\dot{v}} - m)\dot{v} + (Y_{\dot{r}} - m x_G)\dot{r} \\ &+ Y_{uv}uv + (Y_{ur} - m)ur \\ &+ Y_{v|v}|v| + Y_{r|r}|r| + Y_{v|r}|v|r| \end{aligned} \quad (24)$$

An oblique towing test is performed with a  $(x_0, y_0, \psi)$ -mechanism with speed controlled towing carriage by following reference trajectory:

$$[s^{(0)}] = [u_0^{(0)}, 0, \beta^{(0)}]^T \quad (25)$$

yielding to the following reference lateral force:

$$Y(0) = -u_0^{(0)2} (Y_{uv} \cos \beta^{(0)} + Y_{v|v} \sin \beta^{(0)} |\sin \beta^{(0)}|) \quad (26)$$

The influence of speed fluctuations of the main  $(x_0)$  carriage is investigated:

$$[s] = [u_0^{(0)} + u_{0A}^{(E)} \cos(\alpha\omega t + \phi), 0, \beta^{(0)}]^T \quad (27)$$

The first order error on the lateral force is:

$$\begin{aligned} Y^{(1)} &= \\ &2Y_{uv}u_0^{(0)}u_{0A}^{(E)} \sin \beta^{(0)} \cos \beta^{(0)} \cos(\alpha\omega t + \phi) \\ &+ 2Y_{vv}u_0^{(0)}u_{0A}^{(E)} \sin \beta^{(0)} |\sin \beta^{(0)}| \cos(\alpha\omega t + \phi) \\ &- (Y_{\dot{v}} - m)\alpha\omega u_{0A}^{(E)} \sin \beta^{(0)} \sin(\alpha\omega t + \phi) \end{aligned} \quad (28)$$

which causes following relative error on the lateral force after integration over an interval T:

$$\frac{Y^{(1)[0]}}{Y^{(0)[0]}} = \frac{2u_{0A}^{(E)}}{u_0^{(0)}} \left[ \begin{aligned} &\left( \frac{\sin 2\pi\alpha}{2\pi\alpha} - C_1 (\cos 2\pi\alpha - 1) \right) \cos \phi \\ &+ \left( \frac{\cos 2\pi\alpha - 1}{2\pi\alpha} - C_1 \sin 2\pi\alpha \right) \sin \phi \end{aligned} \right] \quad (29)$$

with

$$C_1 = \frac{1}{2\ell'} \frac{Y'_{\dot{v}} - m'}{Y'_{uv}} \frac{1}{\cos \beta_0 + \frac{Y'_{v|v}}{Y'_{uv}} |\sin \beta_0|}$$

$\ell' = u_0^{(0)}T / L$  being the number of ship lengths covered during the integration interval. Hydrodynamic coefficients are non-dimensionalised with respect to ship length. (29) depends on f, with following upper limit:

$$\left( \frac{Y^{(1)[0]}}{Y^{(0)[0]}} \right)_{\max} = 2 \frac{u_{0A}^{(E)}}{u_0^{(0)}} \frac{\sqrt{2(1 - \cos 2\pi\alpha)}}{2\pi\alpha} \sqrt{1 + (2\pi\alpha C_1)^2} \quad (30)$$

$$\equiv 2 \frac{u_{0A}^{(E)}}{u_0^{(0)}} f_1(2\pi\alpha; C_1)$$

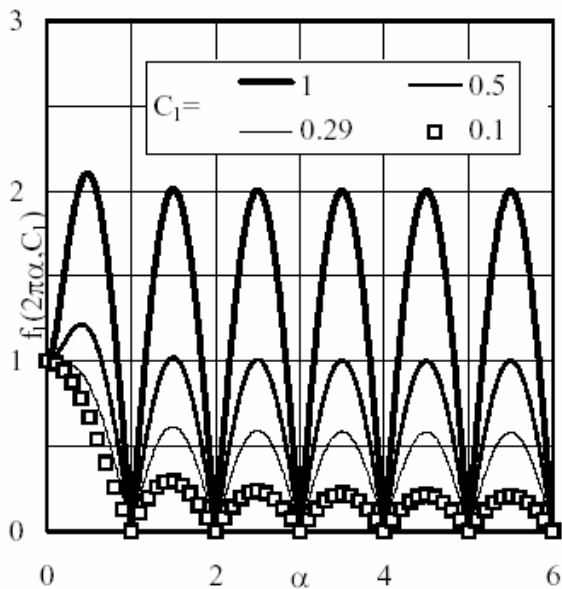

Figure 10. Function  $f_1(2\pi\alpha, C_1)$  for different  $C_1$

The function  $f_1$  is displayed in Figure 10. Irrespective  $C_1$ ,  $f_1(0; C_1) = 1$  and  $f_1(2pn; C_1) = 0$ , which confirms that the relative error on the lateral force is twice the relative error on the carriage speed if the latter is constant, and that fluctuations integrated over an integer number of periods do not affect the test results. The location of the maximum depends on  $C_1$ : for  $C_1 < 12^{-1/2} \approx 0.29$ , it is reached at  $\alpha=0$ ; for larger  $C_1$ , the relative error due to speed fluctuations may

exceed the static error. For higher frequency fluctuations, the local maxima tend to  $2C_1$ , so that for  $C_1=0.5$  they may cause the same relative error on the lateral force than static speed deviations. (29) shows that  $C_1$  depends on the hydrodynamic derivatives of the model, but also on the integration length; for *Esso Osaka* (Table 6), Fig.11 displays the values of  $\ell'$  resulting into the critical  $C_1$  values 0.5 and  $12^{-1/2}$ .

$Y'_{uv}$	-20.9E-3	$N'_r$	-906.E-6
$Y'_v$	-16.9E-3	$N'_v$	-282.E-6
$Y'_{v v }$	-15.1E-3	$m'$	18.4 E-3
$N'_{uv}$	-3.39E-3	$I'_{zz}$	1.15 E-3
$N'_{uv}$	-9.10E-3	$x'_G$	31.8E-3

Table 6: Main manoeuvring coefficients for the *Esso Osaka* (Bogdanov et al, 1987)

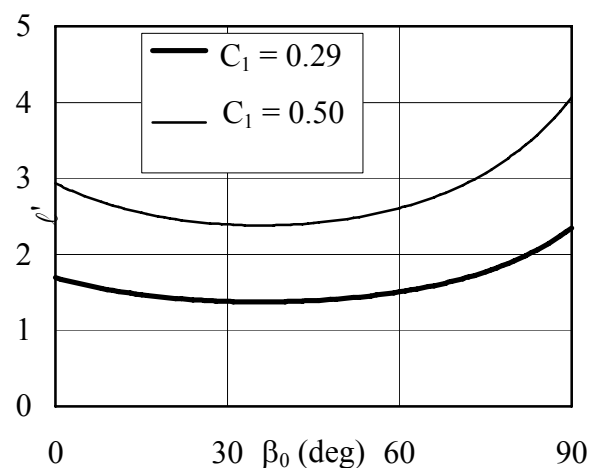



Figure 11: *Esso Osaka* ( $h/T = 8$ ): required measuring length for obtaining specified  $C_1$ .

 INTERNATIONAL TOWING TANK CONFERENCE	<b>ITTC – Recommended Procedures and Guidelines</b>	<b>7.5 - 02 06 - 02.2</b> Page 24 of 27	
	<b>Testing and Extrapolation Methods Manoeuvrability Captive Model Test Procedures</b>	Effective Date 2005	Revision 02

#### 4.2.5.2 Example 2: Harmonic yaw: influence of heading fluctuations on yaw moment

Although a similar methodology can be followed for a complete mathematical model, a linear model is used for this example:

$$N = (N_{\dot{v}} - mx_G)\dot{v} + (N_{\dot{r}} - I_{zz})\dot{r} + N_{uv}uv + (N_{ur} - mx_G)ur \quad (31)$$

A harmonic pure yaw test can be performed by a position controlled  $(x_0, y_0, \psi)$ -mechanism with following reference trajectory:

$$\mathbf{s}^{(0)} = \begin{bmatrix} \frac{u^{(0)}}{\omega} \int_0^{\omega t} \cos(\psi_A \sin \omega t) d\omega t \\ \frac{u^{(0)}}{\omega} \int_{\frac{1}{2}\pi}^{\omega t} \sin(\psi_A \sin \omega t) d\omega t \\ \psi_A \sin \omega t \end{bmatrix} \quad (32)$$

yielding following reference for the first harmonic of the yawing moment:

$$\begin{aligned} \tilde{N}^{(0)[1]} &= N_R^{(0)[1]} + iN_I^{(0)[1]} \\ &= \frac{1}{\pi c} \int_{\varepsilon_k^{[1]}}^{2\pi + \varepsilon_k^{[1]}} N^{(0)}(t) \cos \omega t d\omega t \\ &\quad + i \frac{1}{\pi c} \int_{\varepsilon_l^{[1]}}^{2\pi + \varepsilon_l^{[1]}} N^{(0)}(t) \sin \omega t d\omega t \\ &= -(N_{ur} - mx_G)u^{(0)}\omega\psi_A \\ &\quad - i(N_{\dot{r}} - I_{zz})\omega^2\psi_A \end{aligned} \quad (33)$$

Yaw table fluctuations are investigated:

$$\mathbf{s} = \mathbf{s}^{(0)} + \begin{bmatrix} 0 \\ 0 \\ \psi_A^{(E)} \cos(\alpha\omega t + \phi) \end{bmatrix} \quad (34)$$

The relative errors on the cosine and sine components of the yawing moment due to this fluctuation depends on the phase angle  $\phi$  of the error; again, the upper limit is considered. On the other hand, the integration phase angles  $\varepsilon_R^{[1]}$  and  $\varepsilon_I^{[1]}$  influence these as well:

$$\text{if } \varepsilon_R^{[1]} = (j + \frac{1}{2})\pi. \quad (35)$$

$$\left| \frac{N_{Rc}^{[1](1)}}{N_R^{[1](0)}} \right|_{\max} = \left| \frac{N'_{ur} - N'_{\dot{v}}}{N'_{ur} - m'x'_G} f_2(\alpha, c, C_1, C_2) \frac{\psi_A^{(E)}}{\psi_A} \right|$$

$$\text{if } \varepsilon_R^{[1]} = j\pi.$$

$$\left| \frac{N_{Rs}^{[1](1)}}{N_R^{[1](0)}} \right|_{\max} = \left| \frac{N'_{ur} - N'_{\dot{v}}}{N'_{ur} - m'x'_G} \cdot \alpha f_2(\alpha, c, C_1, C_2) \frac{\psi_A^{(E)}}{\psi_A} \right| \quad (36)$$

$$\text{if } \varepsilon_I^{[1]} = j\pi.$$

$$\left| \frac{N_{Is}^{[1](1)}}{N_I^{[1](0)}} \right|_{\max} = \left| \frac{N'_{ur} - N'_{\dot{v}}}{N'_{\dot{r}} - I'_{zz}} \frac{1}{\omega_1} \cdot f_2(\alpha, c, C_1, C_2) \frac{\psi_A^{(E)}}{\psi_A} \right| \quad (37)$$

$$\text{if } \varepsilon_I^{[1]} = (j + \frac{1}{2})\pi:$$

$$\left| \frac{N_{Ic}^{[1](1)}}{N_I^{[1](0)}} \right|_{\max} = \left| \frac{N'_{ur} - N'_{\dot{v}}}{N'_{\dot{r}} - I'_{zz}} \frac{1}{\omega_1} \cdot \alpha f_2(\alpha, c, C_1, C_2) \frac{\psi_A^{(E)}}{\psi_A} \right| \quad (38)$$

with

$$f_2(\alpha, c, C_1, C_2) \quad (39)$$

$$f_2(\alpha, c, C_1, C_2) = \left| \frac{2\alpha^2 \sqrt{2(1 - \cos 2\pi\alpha)}}{\alpha^2 - 1} \frac{1}{2\pi\alpha} \right| \cdot \sqrt{1 + \left[ 2\pi\alpha C_1 + \frac{C_2}{2\pi\alpha} \right]^2}$$

$$C_1 = \frac{N'_{\dot{r}} - I'_{zz} \omega'_1}{N'_{ur} - N'_{\dot{v}} 2\pi}; C_2 = \frac{N'_{uv}}{N'_{ur} - N'_{\dot{v}} \omega'_1} 2\pi \quad (40)$$

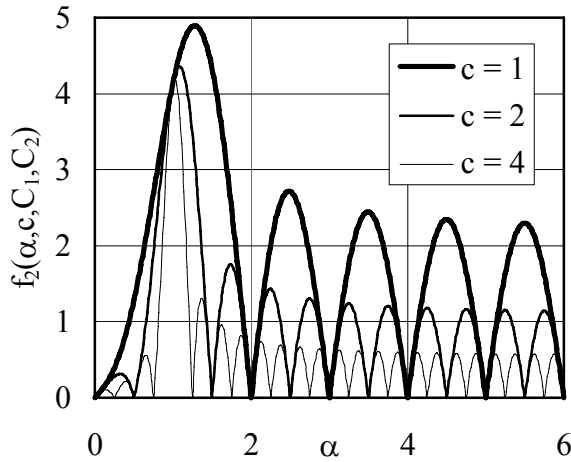

Figure 12:  $f_2$  as a function of  $\alpha$  for different number of oscillation cycles ( $C_1 = 0.552$ ;  $C_2 = 3.52$  - *Esso Osaka*,  $h/T = \infty$ ,  $\omega'_1 = 5.23$ ).

For given  $C_1$  and  $C_2$ ,  $f_2$  is plotted in Figure 12 for several numbers of cycles  $c$  as a function of  $\alpha$ . A distinction should be made according to the frequency of the disturbances.

For large  $\alpha$ ,  $f_2$  varies between 0 and  $4C_1/c$ , so that the influence of higher frequency fluctuations decreases with increasing number of cycles  $c$  and decreasing test frequency  $\omega'_1$ . Their effect can be largely reduced by selecting proper integration phase angles ( $\varepsilon_R^{[1]}$ ,  $\varepsilon_I^{[1]}$ ), as

is clarified by comparing (35) and (37) with (36) and (38), respectively.

The effect of low frequency fluctuations is maximal for a value of  $\alpha$ , which depends on the number of cycles  $c$ , and reaches 1 if  $c \rightarrow \infty$ , which means that fluctuations varying with the test frequency may  $\omega$  cause the largest errors. For  $\alpha = 1$ ,  $f_2$  equals:

$$\lim_{\alpha \rightarrow 1} f_2(\alpha, c, C_1, C_2) = \sqrt{1 + \left[ 2\pi C_1 + \frac{C_2}{2\pi} \right]^2} \quad (41)$$

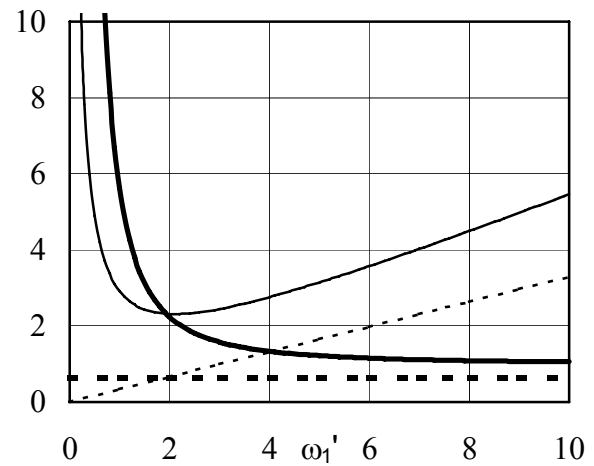

	$\left( \frac{N_{Rc}^{[1](1)}}{N_R^{[1](0)}} \div \frac{\psi_A^{(E)}}{\psi_A} \right)$	$\left( \frac{N_{Is}^{[1](1)}}{N_I^{[1](0)}} \div \frac{\psi_A^{(E)}}{\psi_A} \right)$
$\alpha = 1$	—	—
$\alpha \rightarrow \infty$ ( $c=1$ )	—	—

Figure 13: PMM yaw test: influence of test frequency on effect of yaw angle fluctuations on first harmonic components of yawing moment (*Esso Osaka*,  $h/T = \infty$ )

	<b>ITTC – Recommended Procedures and Guidelines</b>	<b>7.5 - 02 06 - 02.2</b> Page 26 of 27	
	<b>Testing and Extrapolation Methods Manoeuvrability Captive Model Test Procedures</b>	Effective Date 2005	Revision 02

For the *Esso Osaka*, the effect of low and higher frequency yaw angle fluctuations on the first harmonic components of the yawing moment is plotted as a function of  $\omega_1'$  in Figure 13.

### 4.3 Benchmark Tests

- 1) Preliminary Analysis of ITTC Co-operative Tests Programme (11<sup>th</sup> 1966 pp.486-508) A Mariner Class Vessel
- 2) The I.T.T.C. Standard Captive-Model-Test Program (11<sup>th</sup> 1966 pp.508-516) A Mariner Type Ship "USS COMPASS ISLAND"
- 3) Co-operative Tests for ITTC Mariner Class Ship Rotating Arm Experiments (12<sup>th</sup> 1969 pp.667-670) A MARINER Model
- 4) The Co-operative Free-Model Manoeuvring Program (13<sup>th</sup> 1972 pp.1000)
  - 4-1) Co-operative Test Program - Second Analysis of Results of Free Model Manoeuvring Tests (13<sup>th</sup> 1972 pp.1074-1079) A MARINER Type Ship
  - 5) The Co-operative Captive-Model Test Program (13<sup>th</sup> 1972 pp.1000) To Determine the Ability with which Full-Scale Ship Trajectories Could Be Predicted from the Test Data Acquired.
    - 5-1) Co-operative Tests Program - Review and Status of Second Phase of Standard Captive-Model Test Program (13<sup>th</sup> 1972 pp. 1080-1092)
- 6) The Mariner Model Cooperative Test Program - Correlations and Applications (14<sup>th</sup> 1975 Vol.2 pp.414-427) A New Large Am-

plitude PLANAR MOTION MECHANISM, The MARINER Model

- 7) Comparative Results from Different Captive Model Test Techniques (14<sup>th</sup> 1975 Vol.2 pp.428-436) A MARINER CLASS Vessel and a Tanker Model
- 8) Ship Model Correlation in Manoeuvrability (17<sup>th</sup> 1984 pp.427-435) To Conduct Model Tests and Compare Their Results with "ESSO OSAKA" Deep and Shallow Water Trials Joint International Manoeuvring Program (JIMP). A Working Group Called JAMP (Japan Manoeuvrability Prediction)
- 9) Free-Running Model Tests with ESSO OSAKA (18<sup>th</sup> 1987 pp.369-371)
- 10) Captive Model. Tests with ESSO OSAKA (18<sup>th</sup> 1987 pp.371-376)

### 5. REFERENCES

- International Towing Tank Conference, 1996, "Manoeuvring Committee - Final Report and Recommendations to the 21<sup>st</sup> ITTC", Proceedings of 21<sup>st</sup> ITTC, Bergen-Trondheim, Norway, Vol. 1, pp. 347-398.
- International Towing Tank Conference, 1999, "Manoeuvring Committee - Final Report and Recommendations to the 22<sup>nd</sup> ITTC", Proceedings of 22<sup>nd</sup> ITTC, Seoul/Shanghai.
- Bogdanov, P., Vassilev, P., Lefterova, M., Milanov, E., 1987, "'Esso Osaka' tanker manoeuvrability investigations in deep and shallow water, using PMM", International Shipbuilding Progress, Vol. 34, No. 390, p. 30-39.

	<b>ITTC – Recommended Procedures and Guidelines</b>	<b>7.5 - 02 06 - 02.2</b> Page 27 of 27	
	<b>Testing and Extrapolation Methods Manoeuvrability Captive Model Test Procedures</b>	Effective Date 2005	Revision 02

- Brard, R., 1948, "Introduction à l'étude théorique du tangage en marche", Bulletin de l'ATMA, No. 47, p. 455-479.
- Goodman, A., Gertler, M., Kohl, R., 1976, "Experimental technique and methods of analysis used at Hydronautics for surface-ship manoeuvring predictions", 11<sup>th</sup> Symposium on Naval Hydrodynamics, London, UK, p.55-113.
- Leeuwen, G. van, 1964, "The lateral damping and added mass of an oscillating ship model", Shipbuilding Laboratory, Technological University Delft, Publication No. 23.
- Leeuwen, G. van, 1969, "Some problems concerning the design of a horizontal oscillator" (in Dutch), Shipbuilding Laboratory, Technological University Delft, Report No. 225.
- Milanov, E., 1984, "On the use of quasisteady PMM-test results", International Symposium on Ship Techniques, Rostock, Germany.
- Nomoto, K., 1975, "Ship response in directional control taking account of frequency dependent hydrodynamic derivatives", Proceedings of the 14<sup>th</sup> ITTC, Ottawa, Canada, Vol. 2, p.408-413.
- Vantorre, M., 1988, "On the influence of the accuracy of planar motion mechanisms on results of captive manoeuvring tests", Scientific and Methodological Seminar on Ship Hydrodynamics, 17<sup>th</sup> session, Varna, Bulgaria, Vol. 1, p.28.1-8.
- Vantorre, M., 1989, "Accuracy considerations and optimization of parameter choice of captive manoeuvring tests with ship models" (in Dutch), DSc thesis State University of Ghent, Ghent, Belgium.
- Vantorre, M., 1992, "Accuracy and optimization of captive ship model tests", 5<sup>th</sup> International Symposium on Practical Design of Ships and Mobile Units, Newcastle upon Tyne, UK, Vol. 1, p.1.190-1.203.
- Vantorre, M., Eloit, K., 1997, "Requirements for standard harmonic captive manoeuvring tests", MCMC'97, Brijuni, Croatia, p.93-98.
- Wagner Smitt, L., Chislett, M.S., 1974, "Large amplitude PMM tests and manoeuvring predictions for a Mariner class vessel", 10<sup>th</sup> Symposium on Naval Hydrodynamics, Boston, USA, p.131-157.
- Wehausen, J.V., Laitone, E.V., 1960, "Surface waves", Encyclopedia of Physics, Vol. 9, p.446-778, Springer Verlag, Berlin, Germany.