	ITTC – Recommended Procedures and Guidelines	7.5-02 -03-02.1 Page 1 of 10	
	Testing and Extrapolation Methods Propulsion, Propulsor Open Water Test	Effective Date 2008	Revision 02

Table of Contents

Open Water Tests.....2 1. PURPOSE OF PROCEDURE2 2. PARAMETERS:.....2 2.1 Data Reduction Equations2 2.2 Definition of Variables2 3. PROCEDURE.....3 3.1 Model and Installation3 3.1.1 Model3 3.1.2 Installation.....3 3.2 Measurement Systems5 3.3 Instrumentation6 3.3.1 General remarks6 3.3.2 Thrust6 3.3.3 Torque7 3.3.4 Rate of revolution.....7 3.3.5 Speed.....7	3.3.6 Temperature7 3.4 Calibrations.....7 3.4.1 General remarks7 3.4.2 Propeller dynamometer:.....7 3.4.3 Rate of revolutions8 3.4.4 Speed.....8 3.4.5 Thermometer.....8 3.5 Test Procedure and Data Acquisition.....8 3.6 Data Reduction and Analysis.....9 3.7 Documentation9 4. VALIDATION.....9 4.1 Uncertainty Analysis9 4.2 Benchmark Tests10 5. REFERENCES10
--	--

Updated by	Approved
Propulsion Committee of 25 th ITTC:	25 th ITTC 2008
Date February 2008	Date 09/2008

Open Water Tests

1. PURPOSE OF PROCEDURE

The purpose of the procedure is to ensure consistency of methodology and acquisition of correct results from Propeller Open Water Tests.

The propeller open water characteristics are used in the analysis of the Propulsion Tests and the estimation of the required power. The procedure addresses model scale only and does not consider extrapolation and full scale prediction.

The procedure is generally applicable for open water tests performed with conventional propellers, ducted propellers and tip-plate propellers. For podded propeller open water test procedure please refer to 7.5-02-03-01.3-Podded Procedure Propulsor Tests and Extrapolation

2. PARAMETERS:

2.1 Data Reduction Equations

Thrust Coefficient $K_T = \frac{T}{\rho \cdot n^2 D^4}$

Torque Coefficient $K_Q = \frac{Q}{\rho \cdot n^2 D^5}$

Ducted Propeller

Duct Thrust Coefficient $K_{TD} = \frac{T_D}{\rho \cdot n^2 D^4}$

Ducted Propeller Thrust Coefficient

$$K_{TP} = \frac{T_P}{\rho \cdot n^2 D^4}$$

Total thrust coefficient for a ducted propeller unit

$$K_{TT} = K_{TP} + K_{TD}$$

Propeller Efficiency in

Open Water

$$\eta_0 = \frac{JK_T}{2\pi K_Q}$$

Advance Coefficient

$$J = \frac{V_A}{nD}$$

Reynolds Number of propeller based on chord length $0.7R$

$$Re = \frac{c_{0.7R} (V_A^2 + (0.7\pi nD)^2)^{1/2}}{\nu}$$

$$Re = \frac{c_{0.7R} (V_A^2 + (0.7\pi nD)^2)^{1/2}}{\nu}$$

2.2 Definition of Variables

$c_{0.7R}$	Chord length at $0.7R$ (m)
D	Propeller diameter (m)
n	Rate of revolutions of the model propeller (rps)
Q	Propeller torque (Nm)
R	Propeller radius (m)
T	Propeller thrust (N)
T_D	Duct (or nozzle) thrust (N)
T_P	Ducted propeller thrust (N)
T_T	Total thrust of a ducted propeller unit (N)
V_A	Speed of advance of the model propeller (m/s)
ρ	Mass density of water (kg/m ³)

	ITTC – Recommended Procedures and Guidelines	7.5-02 -03-02.1 Page 3 of 10	
	Testing and Extrapolation Methods Propulsion, Propulsor Open Water Test	Effective Date 2008	Revision 02

ν Kinematic viscosity (m^2/s)

3. PROCEDURE

3.1 Model and Installation

3.1.1 Model

The model propeller should be manufactured in accordance with Standard Procedure 7.5-01-02-02, Propeller Model Accuracy.

The fairings forward and aft of a conventional pushing propeller should be modelled according to Fig.1.

For a pulling propeller, the nose cone should be modelled accordingly.

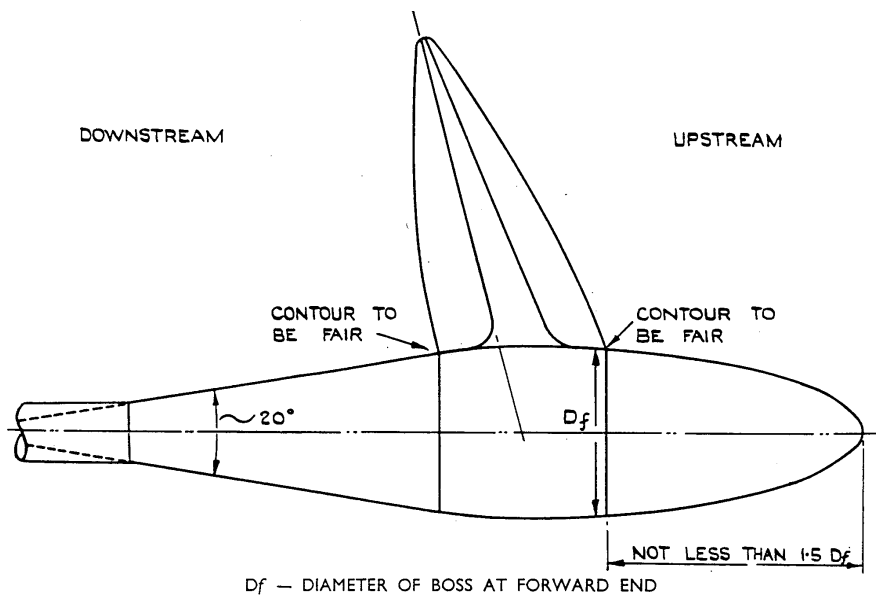



Figure 1 Geometry of Model Fairings

	ITTC – Recommended Procedures and Guidelines	7.5-02 -03-02.1 Page 4 of 10	
	Testing and Extrapolation Methods Propulsion, Propulsor Open Water Test	Effective Date 2008	Revision 02

3.1.2 Installation

3.1.2.1 Conventional Propellers

3.1.2.1.1 Towing Tank

The propeller model is to be mounted on a drive shaft. A streamlined nose cap of sufficient length to ensure that the inflow over the propeller hub is parallel to the shaft should be mounted upstream of the propeller model, Fig.1. In the case of a pulling propeller, the nose cone should be modelled according to the actual propeller geometry. The connection between the cap and the hub should be smooth and without a gap. The size and shape of the nose cap should be recorded. In some cases the nose length may be less than $1.5 D$ as long as the flow is parallel.

In order to eliminate a pressure build-up at the downstream end of the hub and the fixed shaft housing, the rotating part of the hub

should be positioned in such a way to avoid any kind of pressure build-up. The arrangement used should be recorded and included in the test report.

The drive shaft housing should not be too close to the model propeller blades. A distance of not less than $1.5 D$ to $2.0 D$ is recommended, where D is the propeller diameter. The drive shaft should be arranged parallel to the calm water surface and the carriage rails. A typical set up for a towing tank is shown in Fig. 2.

The propeller immersion has to be selected such that air drawing from the water surface is avoided at any test condition. As a guideline, an immersion of the propeller shaft of at least $1.5 D$ is recommended, where D is the diameter of the propeller. The immersion of the shaft centre line should be recorded and included in the test report.

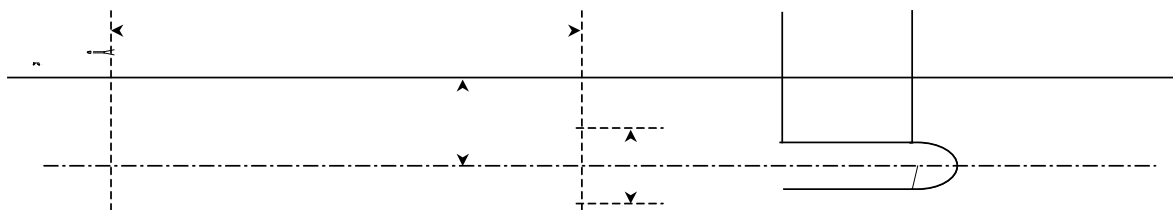



Figure 2 Typical Set Up for Tests on Conventional Propellers in a Towing Tank

	ITTC – Recommended Procedures and Guidelines	7.5-02 -03-02.1 Page 5 of 10	
	Testing and Extrapolation Methods Propulsion, Propulsor Open Water Test	Effective Date 2008	Revision 02

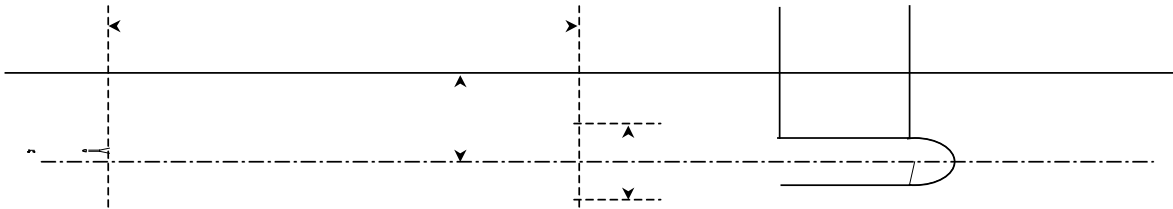



Figure 3 Typical Set Up for Tests on Ducted Propellers in a Towing Tank

	ITTC – Recommended Procedures and Guidelines	7.5-02 -03-02.1 Page 6 of 10	
	Testing and Extrapolation Methods Propulsion, Propulsor Open Water Test	Effective Date 2008	Revision 02

When a current meter is used to measure the speed of advance of the propeller model, the immersion of the current meter should correspond to the immersion of the propeller shaft. The distance between the propeller and the current meter should be selected to ensure that the propeller model is not influenced by the current meter. A distance between the current meter and propeller model of at least $10 D$ is recommended, where D is the diameter of the model propeller.

The dimensions of the tank should be large enough to avoid blockage and should be included in the test report.

3.1.2.1.2 Cavitation Tunnel

The propeller model is to be mounted on a drive shaft. A streamlined nose cap of sufficient length to ensure that the inflow over the propeller hub is parallel to the shaft should be mounted upstream of the propeller model, Fig.1. The connection between the cap and the hub should be smooth and without a gap. The size and shape of the nose cap should be recorded. In some cases the nose length may be less than $1.5 D$ as long as the flow is parallel to the shaft axis. The choice of propeller diameter should be made such that scaling effects are avoided within the blockage constraints of a given cavitation tunnel.

The dimensions of the cavitation tunnel should be included in the test report. For testing in the cavitation tunnel significant cavitation should be avoided and open water tests should be carried out under atmospheric condition.

3.1.2.2 Ducted Propellers

The clearance between the propeller tips and the inner surface of the duct should be kept at the recommended design value. Depending on model scale, this value sometimes cannot be achieved. Then, a maximum of 1.0 mm clearance for a scaled model propeller of about 250mm diameter is considered to be satisfactory. The relative longitudinal position of the propeller and the duct should be adjusted to the design value.

The duct is usually supported by a strut which has a streamlined section shape. Only the force acting on the duct should be measured during the test. A typical set up for a towing tank is shown in Fig.3. The set-up for a cavitation tunnel is similar to that for a towing tank.

The duct thrust is usually measured by a load cell with a shielded strut, or a strain gauge positioned between the duct and the strut. Another method is to measure the drag force acting on the strut separately as a function of advance velocity.

3.2 Measurement Systems

Fig 4. shows the scheme of a typical measuring system

The following quantities are measured:

- Model speed
- Propeller thrust
- Propeller torque
- Propeller rate of revolution
- Duct thrust (if fitted)
- Water temperature (for calculation of viscosity)

	ITTC – Recommended Procedures and Guidelines	7.5-02 -03-02.1 Page 7 of 10	
	Testing and Extrapolation Methods Propulsion, Propulsor Open Water Test	Effective Date 2008	Revision 02

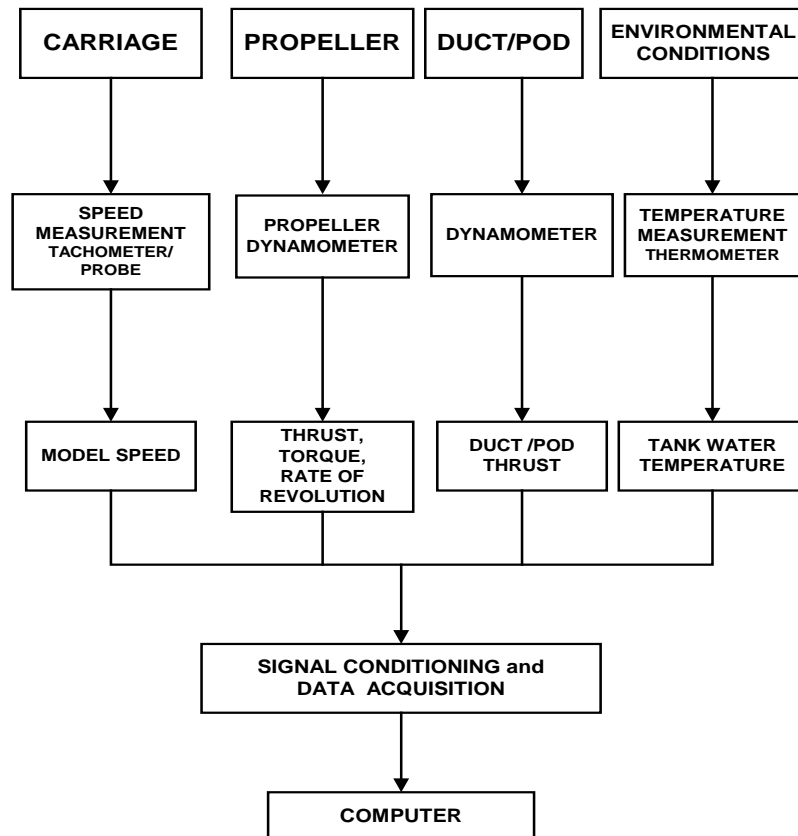

Figure 4 Typical Measurement System

3.3 Instrumentation

3.3.1 General remarks

The performance of a propeller open water test requires the use of a propeller open water dynamometer which enables the measurement of thrust, torque and rate of revolution of the propeller. The quoted bias accuracies are for indicative purposes only. Uncertainty analysis should be used to derive the actual requirements.

3.3.2 Thrust

The propeller thrust is measured using the propeller open water dynamometer. In the case when the propeller is working in a nozzle, the additional thrust or the resistance of the nozzle has to be considered.

The thrust dynamometer should measure the thrust to within 0.2% of the maximum capacity of the dynamometer. This does not nec-

	ITTC – Recommended Procedures and Guidelines	7.5-02 -03-02.1 Page 8 of 10	
	Testing and Extrapolation Methods Propulsion, Propulsor Open Water Test	Effective Date 2008	Revision 02

essarily imply that the thrust itself is measured to within the same tolerance of its true value.

3.3.3 Torque

The propeller torque is measured using the propeller open water dynamometer. In the torque measurement, it is essential to keep the shaft friction losses as low as possible.

The torque dynamometer should measure the torque to within 0.2% of the maximum capacity of the dynamometer. This does not necessarily imply that the torque itself is measured to within the same tolerance of its true value.

3.3.4 Rate of revolutions

The rate of revolutions of the propeller should be constant throughout the test run. Steadiness of the rate of revolution is essential in achieving reliable results.

The measurement instrumentation should measure the rate of revolutions to within 0.2% of the maximum rate of revolutions. This does not necessarily imply that the rate of revolutions itself is measured to within the same tolerance of its true value.

3.3.5 Speed

The speed of the propeller model should be measured to within 0.1% of the maximum carriage speed or within 3 mm/sec, whichever is the larger for towing tanks. In cavitation tunnels the speed should be measured within 1% of the maximum tunnel axial speed.

3.3.6 Temperature

The water temperature should be measured at the propeller shaft level using a thermometer.

3.4 Calibrations

3.4.1 General remarks

All devices used for data acquisition should be calibrated regularly. For calibration, the measured quantities should be either substituted by calibrated weights and pulses or checked by other measuring devices which have already been calibrated. Calibration diagrams, where the measured quantities (output values) are plotted against the calibration units (input units), may be useful to check the calibration itself, as well as the linearity of strain gauge or inductive instruments. Calibration should generally be in accordance with ITTC Recommended Procedure 7.6-01-01.

Calibrations should preferably include as much of the measurement chain as possible (amplifier, filter, A/D converter). If the check indicates that the required accuracies cannot be met, the calibration should be renewed or the instrument replaced and the check repeated. Daily checking of a pulse counter for speed measurements is usually not required. Instead, the check on this device is covered by calibrations carried out at regular intervals.

3.4.2 Propeller dynamometer:

3.4.2.1 Propeller Thrust

The calibration of the propeller open water dynamometer in respect of the propeller thrust should be carried out statically and, if possible, dynamically with calibrated weights. The dynamic calibration should be carried out at various rates of revolution.

	ITTC – Recommended Procedures and Guidelines	7.5-02 -03-02.1 Page 9 of 10	
	Testing and Extrapolation Methods Propulsion, Propulsor Open Water Test	Effective Date 2008	Revision 02

3.4.2.2 Propeller Torque

The calibration of the propeller open water dynamometer in respect of the propeller torque should be carried out statically and, if possible, dynamically. For the static calibration, calibrated weights are applied to a lever of known length to simulate a moment on the dynamometer shaft. The dynamic calibration should be carried out, for example, by use of an eddy current brake

3.4.3 Rate of revolution

The calibration of the respective devices should be carried out by use of precise motor speed transmitters.

3.4.4 Speed

The calibration of the carriage speed or tunnel axial speed will depend mainly on how the speed is measured in each facility. The speed should be checked regularly and respective records should be stored.

3.4.5 Thermometer

Thermometers should be calibrated according to common standards and/or following the advice of the manufacturer, and should have an accuracy of not less than 0.1°C .

3.5 Test Procedure and Data Acquisition

Prior to the tests, runs should be made to measure the influence of the streamlined nose cap. These measurements should be carried out with a propeller hub without blades, having the same shape as the real propeller hub. This hub should have the same weight as the propeller. Before and after each test series, the zero reference values of thrust and torque are determined.

Zeros should be checked between runs to ensure no drift has occurred. The range of measurements should cover that of the open water tests in terms of rotational speed and speed of advance. The way these measurements are carried out, and the results, should be recorded.

In the case of pulling propellers (where the propeller is ahead of a bossing) the influence of the propeller cap on the thrust and torque of the propeller is not relevant, as the propeller is tested in the same configuration as that used behind the ship.

During each open water test run, the values of thrust, torque, rate of revolution and speed of advance are recorded simultaneously. When the propeller works in a nozzle, or is designed to be used on pods or conventional Z-drives, the forces of such devices in the direction of the propeller shaft should also be measured.

The range of advance coefficients should cover the range from $J = 0$ until $K_T < 0$, in order to determine accurately the point at which $K_T = 0$.

There should be sufficient waiting time between consecutive runs in order to achieve similar conditions and to obtain consistent results. This waiting time will depend on the size and type of model, model speed and test facility. The waiting times should be recorded.

The propeller open water tests should be conducted at least at two Reynolds Numbers; one should be at the Reynolds Number used for the evaluation of the propulsion test, which should be not lower than $2 \cdot 10^5$ and the other should be as high as possible.

	ITTC – Recommended Procedures and Guidelines	7.5-02 -03-02.1 Page 10 of 10	
	Testing and Extrapolation Methods Propulsion, Propulsor Open Water Test	Effective Date 2008	Revision 02

3.6 Data Reduction and Analysis

The model data derived from the experiment, namely thrust, torque and rate of revolution, should be plotted against the speed of advance. The measured thrust and torque are to be corrected for the effect of the streamlined nose cap, as determined before and/or after the actual open water test. In the case of cavitation tunnel experiments the measured velocity, thrust and torque values are corrected for tunnel wall effects based on the work of Wood and Harris. The respective curves should be faired and the model values corresponding to required speeds of advance should be taken from the diagram.

The measured duct force (resistance or thrust) should be corrected for the effect of the (streamlined) support strut, as determined before or after the actual open water test.

Values of water density and viscosity should be determined according to ITTC Recommended Procedure 7.5-02-01-03.

The required values of K_T , (K_{TD}), K_Q , η_0 and J are calculated according to the data reduction equations given in Section 2.1.

3.7 Documentation

The results from the test should be collated in a report which should contain at least the following information:

- Model Propeller Specification:
 - Identification (model number or similar)
 - Model scale
 - Main dimensions and particulars (see recommendations of ITTC Recommended Procedure 7.5-01-01-01 Ship Models)

Immersion of centreline of propeller shaft in the case of towing tank

- Particulars of the towing tank or cavitation tunnel, including length, breadth and water depth or test section length, breadth and height.
- Test date
- Parametric data for the test:
 - Water temperature
 - Water density
 - Kinematic viscosity of the water
 - Reynolds Number (based on propeller blade chord at $0.7R$)
- For each speed the following data should be given as a minimum:
 - Thrust and torque of the propeller
 - Rate of revolution
 - Force of nozzle in the direction of the propeller shaft

4. VALIDATION

4.1 Uncertainty Analysis

Uncertainty analysis should be performed in accordance with Uncertainty Analysis in EFD, Uncertainty Assessment Methodology as described in QM 7.5-02-01-01 and Uncertainty Analysis in EFD, Guidelines for Uncertainty Assessment as described in QM 7.5-02-01-02. In addition to the above, an example Uncertainty Analysis Example for Propeller Open Water Test is provided in ITTC Recommended Procedure 7.5-02-03-2.2.

	ITTC – Recommended Procedures and Guidelines	7.5-02 -03-02.1 Page 11 of 10	
	Testing and Extrapolation Methods Propulsion, Propulsor Open Water Test	Effective Date 2008	Revision 02

4.2 Benchmark Tests

Benchmark data are collected and described in 'Benchmark Database for CFD, Validation for Resistance and Propulsion, QM 7.5-03-02-02

Conference, Venice, Italy, ITTC Recommended Procedure 7.5-02-03-02.1, Revision 01.

- (2) Wood and Harris, 1920, Some Notes on the Theory of an Airscrew Working in a Wind Channel, Aeronautical Research Council, R&M 662.

5. REFERENCES

- (1) ITTC 2002, Propulsion, Propulsor Open Water Test, 23rd International Towing Tank